

21
BB
big block



hpi-racing
hobby products international

I-1401-2

Equipment Needed



20% Glow Fuel



Fuel Bottle



Nitro Cleaner

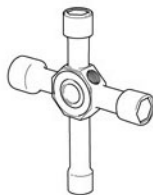

Glow Plug Wrench



Glow Plug Igniter

HPI's Nitro Start-Up Set includes everything you need to run and maintain your engine. Check with your local hobby shop for price and availability.



Not available in the EU.

Recommended

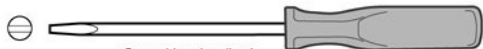

Screwdriver (medium)



Spare Glow Plug

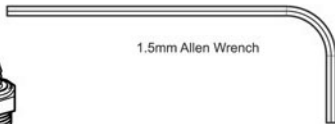

1.5mm Allen Wrench

Step 1: Engine Break-In

1

Use a box or a stand to elevate the vehicle so that the wheels can spin freely without contacting the ground.

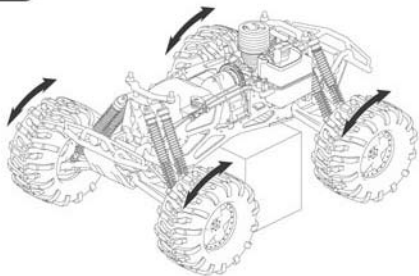

2

Fill the tank completely with fuel. Use only 20% Nitro content fuel. Use only good quality branded model car fuel. Using the wrong fuel could void your warranty.

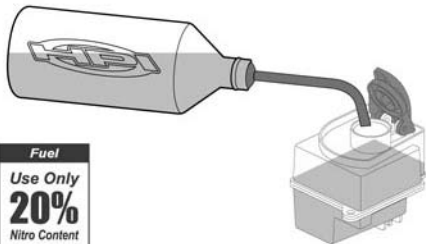

3

Prime the carburetor by pressing the fuel tank primer until fuel reaches the carburetor. Once fuel has completely filled the fuel line (no air bubbles) continue to press the primer button 4 more times.

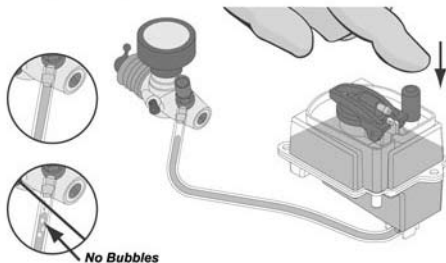

4

Make sure the receiver switch is off. Manually turn the throttle servo by hand until the carburetor is 1/4 of the way open.

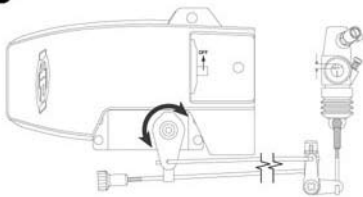

Tip

Always have the air filter in place before the engine is running. Running without the air filter in place will void your warranty.

- 5** Without the glow igniter installed, pull the pull-start 4 times to further prime the engine and incorporate unburned fuel throughout the engine for easy starting. Never pull the starter cord more than 12 inches (30cm) as this can cause damage to the pull-start.

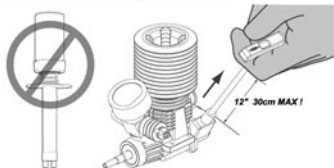
**CAUTION**

DO NOT keep pulling the starter cord if it seems difficult or locks up. The engine could be flooded, see the tips section to remove excess fuel from the engine.

- 7** Turn on the transmitter and receiver, re-fill the fuel tank and follow the starting procedures in steps 3-6. With the tires off the ground, use the radio to slowly increase the throttle until it reaches full speed. This will help clean the excess oil out of the engine. Since the initial break-in settings are very rich, the motor needs to periodically be "cleaned out". If it is not, the left-over oil will load-up the motor and it might shut down.



Tip
To stop engine hold a rag over the exhaust outlet

- 6** Attach the glow igniter to the glow plug. Pull the starter cord using quick short pulls, never pulling it more than 12 inches (30cm). Once the engine is running turn the throttle servo so that the engine runs fast enough to slowly turn the tires. Remove the glow igniter as soon as the engine is running. Run the engine one tank of gas. If the motor shuts off, repeat steps 4-6.

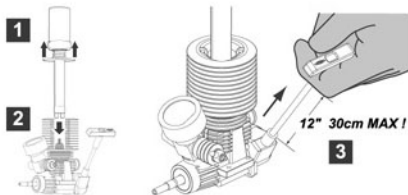

- 8** Place the vehicle on the ground. The vehicle should not move when idling. If it does, adjust the trim setting on the transmitter so the vehicle does not move. Drive the vehicle in a 20 foot (6m) oval applying throttle (below 1/2 throttle), and then coasting. The idea is to use throttle, then coast and let the engine cool, give a little more throttle then coast more to cool. Continue this process for a total of two tanks of fuel.

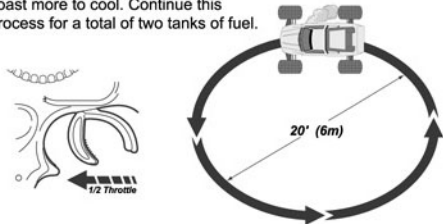

Step 2: Engine Tuning

FACTORY SETTINGS

High-Speed Needle	3 1/2 turns from closed
Low-Speed Needle	3 1/2 turns from closed
Midrange Needle	3 1/4 turns from closed

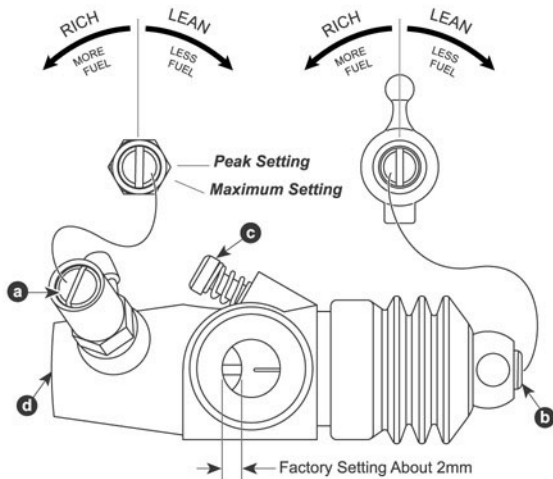

Engine Operating Temperature

DANGER

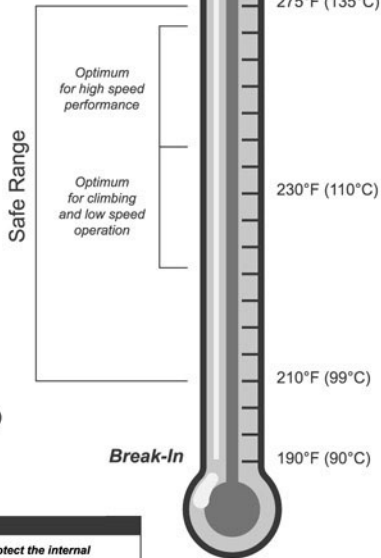

Caution

Too lean of a mixture may not provide the engine with enough lubricant to properly lube and protect the internal components. Your warranty could be voided if the engine is overheated.

a High Speed Needle

The high-speed needle is pre-set from the factory to 3 1/2 turns from fully closed (do not over tighten). After break-in, the needle setting can range from 2 1/2 to 3 turns from fully closed depending on humidity, elevation, fuel, and glow plug. Never run a needle setting that is less than 2 1/2 turns from closed, the motor will run too lean and will overheat causing serious damage! **At full speed** you should see a visible trail of smoke at all times. If the engine sputters at full throttle, the setting of the high speed needle is too lean (not enough fuel). Turn the high-speed needle counter-clockwise in 1/8 turn increments to richen the fuel/air mixture. Continue to adjust the needle in 1/8 turn increments until the sputtering stops. If the engine feels sluggish and bogs at full speed, the high speed needle setting is too rich (too much fuel). Turn the high-speed needle clockwise in 1/8 turn increments to lean out the fuel/air mixture. Continue to adjust the needle in 1/8 turn increments until the power is smooth. Pay attention to the engine temperature. If the engine settings are too lean, the engine will overheat, shut-off, and may become difficult to start. It is always best to run the engine a little on the rich side. This will insure engine longevity and ease of starting.

b Low Speed Needle

The low-speed needle is pre-set from the factory to 3 1/2 turns from fully closed. After break-in, the needle setting will range from 2 1/2 to 3 turns from fully closed depending on humidity, elevation, fuel, and glow plug. Never run a needle setting that is less than 2 1/2 turns from closed, the motor will run too lean and will overheat causing serious damage! With the engine idling, accelerate to full throttle. If the engine emits a heavy amount of smoke and bogs (hesitates) before accelerating or shuts off, the needle setting is too rich (too much fuel). Turn the low-speed needle clockwise in 1/8 turn increments to lean out the fuel/air mixture. Continue to adjust the needle in 1/8 turn increments until the acceleration is smooth. If the engine sputters and shuts off before full throttle acceleration and little or no smoke is visible from the exhaust pipe, the needle settings are too lean. Turn the low-speed needle counter-clockwise in 1/8 turn increments to richen the fuel/air mixture. Continue to adjust the needle in 1/8 turn increments until the acceleration is smooth and the exhaust smoke is visible. The ideal low-speed needle setting will have a quick, smooth acceleration and visible exhaust smoke. If the engine is continually run with improper needle settings, serious damage may occur, shortening the life of the engine.

c Idle Adjustment Screw

Adjust the idle screw so that the engine will idle low enough to keep the engine running without engaging the clutch (wheels turning). The idle adjustment screw is set so that there is a visible gap of approximately 2mm between the throttle body and the throttle slide. This setting also prevents the engine from cutting out when the brakes are applied. Adjust the setting so that the carburetor opening never closes to less than 2mm, even at full brakes.

d Midrange Needle

The midrange adjustment screw is factory pre-set from the factory to 3 1/4 turns from fully closed. It is recommended that you do not adjust the midrange adjustment screw.

Tips Section

Glow Plug Igniter

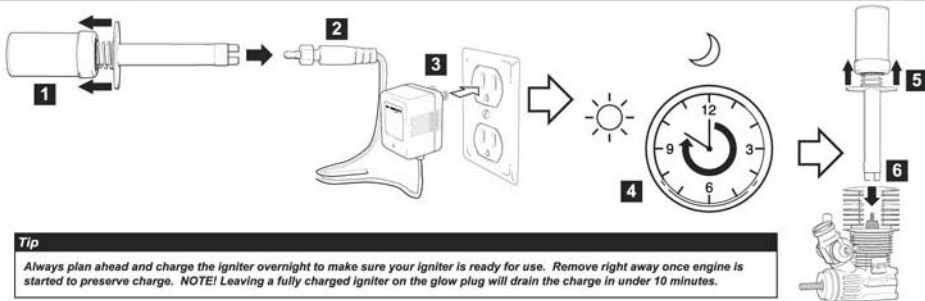

Tip

Always plan ahead and charge the igniter overnight to make sure your igniter is ready for use. Remove right away once engine is started to preserve charge. **NOTE!** Leaving a fully charged igniter on the glow plug will drain the charge in under 10 minutes.

Plug Wrench

Turn the wrench counter-clockwise to remove the glow plug. Turn the wrench clockwise to replace the glow plug.

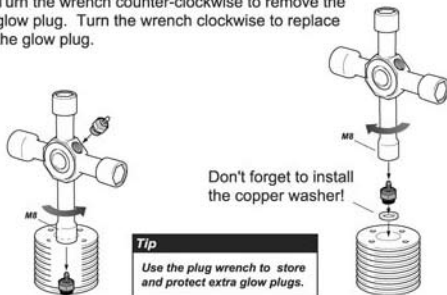

Tip

Use the plug wrench to store and protect extra glow plugs.

Flooded Engine

Remove glow plug using glow plug wrench. Tilt engine head away from face and pull start cord 5-6 times. Replace glow plug and complete starting steps without priming engine.

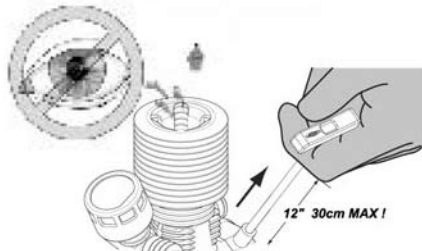

Glow Plug

Use a fully charged glow plug igniter to test the glow plug. Hold the glow plug with needle nose pliers and attach to the igniter. If the plug is good the element will glow an orange or red color. If the element doesn't glow, or if the element is damaged, you will need to replace the plug. The element will be very hot if it is glowing.

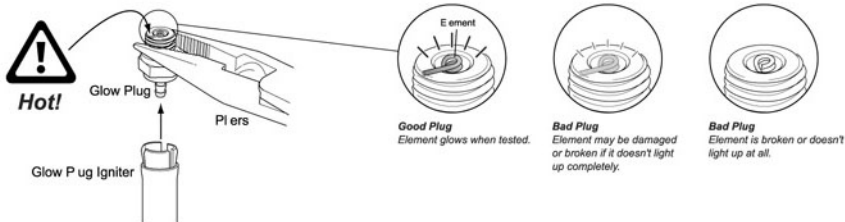

Air Filter

Remove and clean air filter with nitro fuel when soiled. Spray fuel through clean side to insure proper dirt removal. Squeeze filter to remove excess fuel. Recoat filter with air filter oil and reinstall properly, making sure there are no gaps between filter and boot.

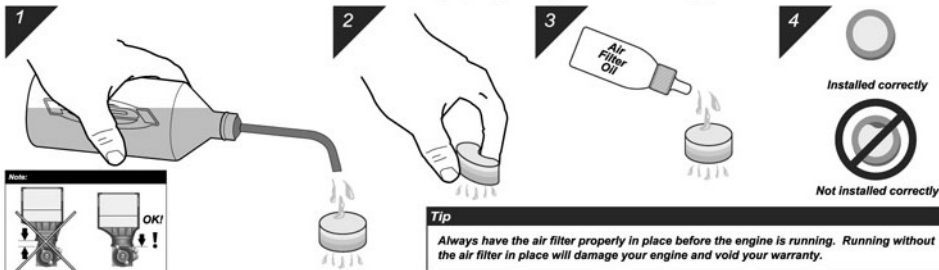

Trouble Shooting

Description	Possible Problem	Solution
Engine does not start	Out of fuel	Refill fuel tank
	Contaminated fuel	Replace fuel
	Glow plug igniter is not charged	Charge glow igniter
	Glow plug is bad	Replace Glow Plug
	No fuel flow	Check fuel lines for crack, leaks, and holes. Replace fuel line if necessary.
	Engine flooded	Remove glow plug and discharge fuel
Engine starts, then stalls	Engine has overheated	Allow engine to cool, richen the fuel mixture and restart
	Throttle valve isn't adjusted properly	Set idle and adjust needle valve to the manufacturers recommended settings
	Air cleaner is blocked	Check air filter. Clean or replace if necessary
	Idle speed is set too low	Adjust the idle speed
Starter cord cannot be pulled	Air bubbles in the fuel line	Check for leaks or crack in the fuel line
	Glow plug is bad	Replace glow plug
	Engine is overheated	Allow engine to cool and then restart
	Airflow though system is bad	Check connections between tank, engine and exhaust
	Throttle servo is improperly set up	Set servo to neutral and reset linkages according to radio and model <u>manufacturer's specifications</u>
Starter cord cannot be pulled	Engine is flooded	Remove glow plug and discharge fuel
	Engine has seized	Check the engine for internal damage.
		Engine may need to be rebuilt or replaced

Maintenance

Keep It Dry

Remove all fuel from the fuel tank and engine when finished running the engine. Fuel that is allowed to sit in the engine when it is stored will cause rust and damage.

Keep It Oiled

If the engine will not be run for an extended period of time, remove the glowplug and put 1-2 drops of after run oil into the cylinder and carb openings. Pull the starter chord 3-4 times to coat the internal parts of the motor and replace the glowplug.

Keep It Clean

Clean outside debris from engine using HPI Nitro Cleaner. Remove any visible dirt. **IMPORTANT:** Do not clean with water as it will cause rust and could void your warranty.

Let It Breathe

Clean or replace the air filter element after long term running or if the air filter becomes dirty. To clean, remove the air filter element and clean with HPI Nitro Fuel. Re-coat the filter element with a proper air filter oil and re-install.

Warranty Cautions

Dirt in Engine

Dirt in the engine is by far the most common cause of major engine damage and voids your warranty. The air filter must be used at all times and be properly seated on the carburetor for it to work properly. Also be sure to clean and oil your air filter element frequently (3-5 tanks) to prevent dirt from working its way into the engine.



ATTENTION



The engine must never be run without the air filter in place!

Low Grade or Bad Fuel

Be sure to purchase quality fuels such as HPI's Power Fuel, manufactured specifically for use in nitro car engines. Use of low grade, old, or improperly stored fuel can lead to decreased performance, shortened engine life, and possibly engine failure.



Over Heating

Probable Cause: The engine is running too lean (not enough fuel) or the motor heatsink head is loose. Check the head bolts to make sure they are tight and then re-adjust the needle settings to the factory specifications.



Keep it Maintained

Poor maintenance will lead to decreased performance and shortened engine life. Dirt caked on the outside of the engine will not allow the engine to efficiently dissipate heat and may cause overheating. To ensure proper cooling, keep the outside of the motor clean and free of dirt and debris.



Warranty Cautions

Dirt In Engine

Dirt in the engine is by far the most common cause of major engine damage and voids your warranty. The air filter must be used at all times and be properly seated on the carburetor for it to work properly. Also be sure to clean and oil your air filter element frequently (3-5 tanks) to prevent dirt from working its way into the engine.



Low Grade or Bad Fuel

Be sure to purchase quality fuels such as HPI's Power Fuel, manufactured specifically for use in nitro car engines. Use of low grade, old, or improperly stored fuel can lead to decreased performance, shortened engine life, and possibly engine failure.



Over Heating

Probable Cause: The engine is running too lean (not enough fuel) or the motor heatsink head is loose. Check the head bolts to make sure they are tight and then re-adjust the needle settings to the factory specifications.



Keep it Maintained

Poor maintenance will lead to decreased performance and shortened engine life. Dirt caked on the outside of the engine will not allow the engine to efficiently dissipate heat and may cause overheating. To ensure proper cooling, keep the outside of the motor clean and free of dirt and debris.



Parts List

NO. 1401 Nitro Star 2188 Engine with Pullstart

<i>Part #</i>	<i>Qty.</i>	<i>Description</i>	<i>Part #</i>	<i>Qty.</i>	<i>Description</i>
1401	1	NITRO STAR 2188 ENGINE WITH PULLSTART	1467	1	LOW SPEED NEEDLE VALVE
1410	1	CYLINDER AND PISTON SET	1468	1	WASHER SET FOR FUEL LINE FITTING
1411	1	CYLINDER, PISTON AND CONNECTING ROD SET	1469	2	O-RING FOR CARBURETOR BODY (2 pcs)
1412	1	CONNECTING ROD	1470	1	MAIN NEEDLE VALVE HOLDER
1413	1	PISTON PIN AND RETAINER SET	1471	1	MAIN NEEDLE
1414	2	RETAINER FOR PISTON PIN (2 pcs)	1472	1	MAIN NEEDLE SET
1415	1	CYLINDER HEAD	1473	1	FUEL LINE FITTING AND WASHER SET
1416	4	SCREW FOR CYLINDER HEAD (4 pcs)	1474	1	IDLE ADJUSTMENT SCREW w/ SPRING
1417	1	UNDERHEAD	1475	1	MIDRANGE NEEDLE VALVE
1418	1	GASKET FOR CYLINDER	1476	1	DUST PROTECTION
1419	1	CRANKCASE	1477	1	UNIBALL
1420	1	BRASS COLLET	1478	1	SLIDE VALVE
1421	1	BALL BEARING 607Z (FRONT)			
1422	1	BALL BEARING 6901 (REAR)			
1424	1	CRANKSHAFT (SG SHAFT)			
1425	1	O RING FOR BACK PLATE			
1427	8	SCREW for BACK PLATE (8 pcs)			
1428	1	PULLSTART ASSY. (w/o ONE-WAY BEARING)			
1429	1	BACK PLATE SET FOR PULL START ENGINE			
1430	1	ONE WAY BEARING FOR PULLSTART			
1431	1	BACK PLATE			
1432	1	STARTING SHAFT			
1433	1	STARTING PIN AND PRESSURE SPRING			
1434	1	LOCK PIN FOR CARBURETOR			
1435	1	O-RING COMPLETE SET			
1461	1	SLIDE CARBURETOR COMPLETE			
1466	1	SLIDE CARBURETOR MAIN BODY			

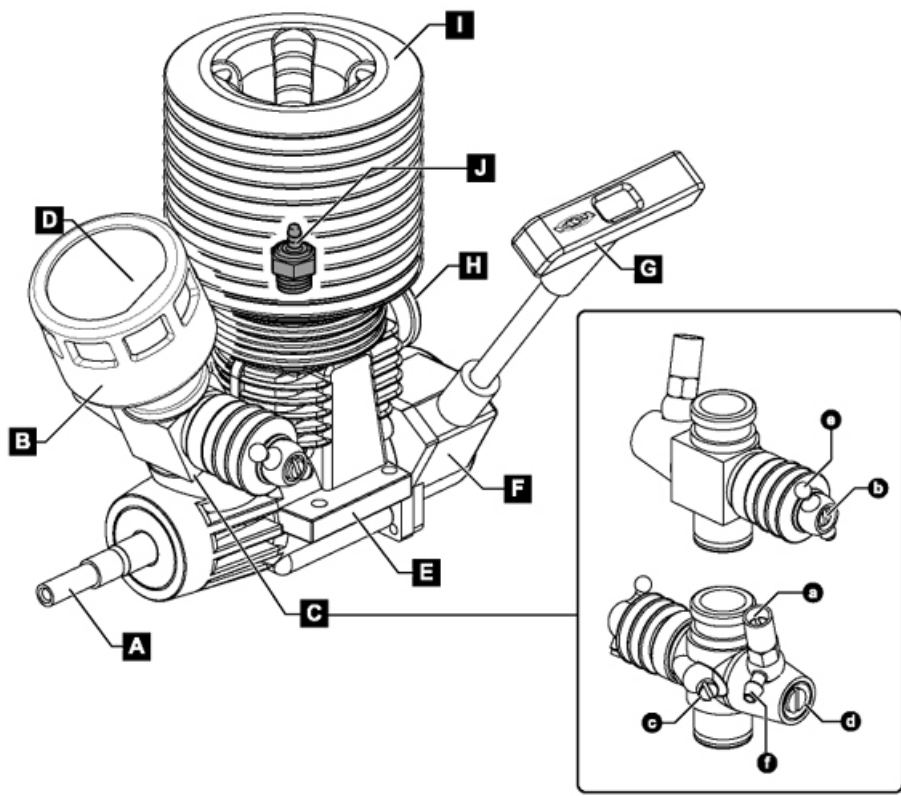

Engine Features

A - Crankshaft	E - Crankcase	I - Heat Sink	a - High Speed Needle	e - Throttle Linkage
B - Air Filter Boot	F - Pull Start Case	J - Glow Plug	b - Low Speed Needle	f - Fuel Inlet
C - Carburetor	G - Pull Start Handle		c - Idle Adjustment Screw	
D - Air Filter	H - Exhaust Outlet		d - Midrange Needle	

Cautions

 **To prevent any serious personal injury and/or damage to property, please be responsible when operating all remote controlled models. Extra attention is called for when operating any glow fuel powered model. These models can exceed speeds of 31 mph (50km/h) and use highly poisonous and flammable fuels.**

Choose the right place to operate your R/C model.

- Do not run on public streets or highways. This could cause serious accidents, personal injuries, and/or property damage.
- Never run R/C models near people or animals.
- To avoid injury, do not run in confined spaces.
- Do not run where loud noises can disturb others, such as hospitals and residential areas.
- Never run indoors. There is a high risk of fire and/or damage.

Inspect your model before operation

- Make sure that all screws and nuts are properly tightened. It is also a good idea to use removable thread lock wherever metal screws go into metal, especially for engine mounts and the engine pilot shaft.
- Always use fresh batteries for your transmitter and for your receiver to avoid losing control of the model.
- Always test the brakes and the throttle before starting your engine to avoid losing control of the model.
- Make sure the air filter is cleaned and oiled. Never run your engine without an air filter.
- Your engine can be seriously damaged if dirt and debris get inside the engine.
- Make sure no one else is using the same radio frequency as you are using.

Heat, Fire, and Fuel Safety

- Never use gasoline in a glow model engine. Use glow fuel specifically designed for car engines. Using non-approved fuels in your engine can cause an explosion.
- Do not smoke or run near open flames while running your model or while handling fuel.
- Always store fuel in a well ventilated place, away from heating devices, open flames, direct sunlight, or batteries.
- Keep glow fuel away from children.
- Be aware that some parts will be hot after operation. Do not touch the exhaust or the engine until they have cooled. These parts may reach 275 degrees fahrenheit during operation!



Glow fuel is flammable and poisonous. Always read the warning label for safety information. Glow fuel powered model engines emit poisonous vapors and gasses. These vapors irritate eyes and can be highly dangerous to you health. We recommend wearing rubber or vinyl gloves to avoid direct contact with glow fuel. Also, be aware of spilled or leaking fuel. Fuel leaks can cause fires or explosions.

5

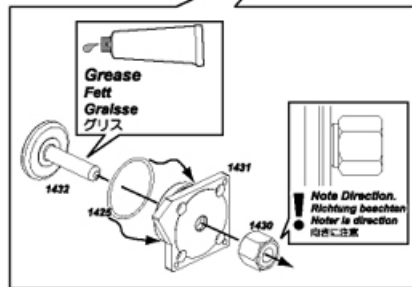
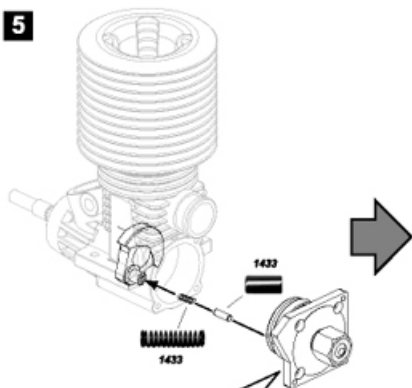

6

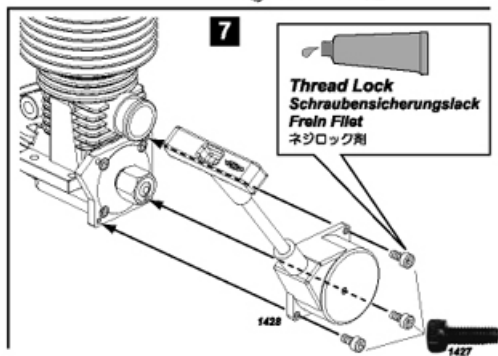
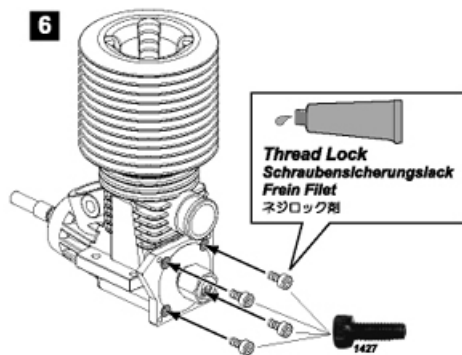

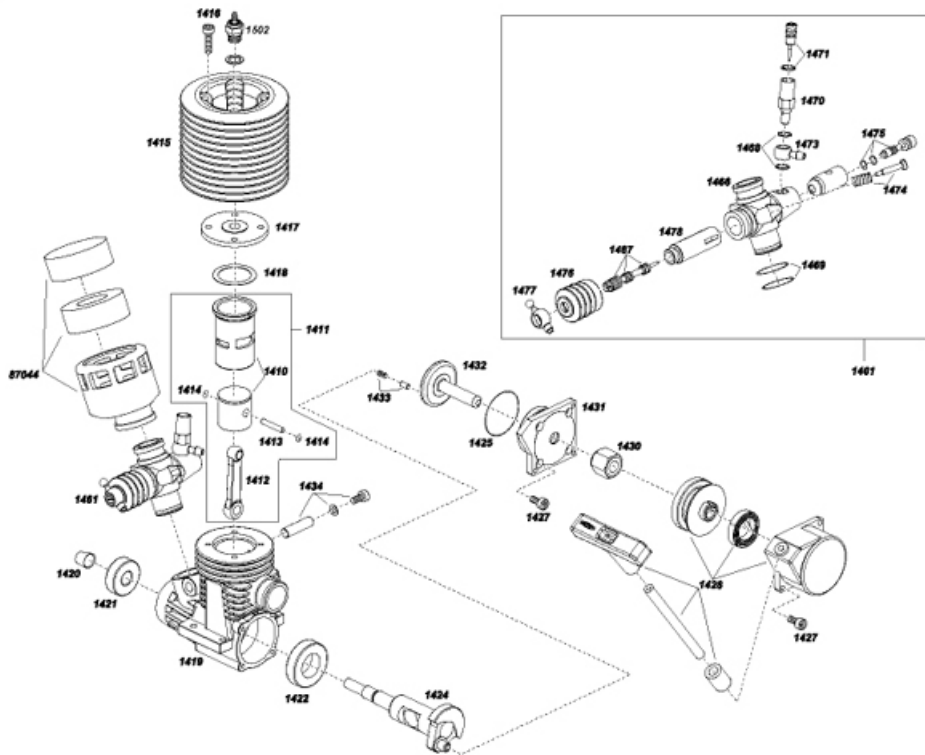

Air Filter Installation
Montage des Luftfilters

Installation de filtre d'air
エアフィルターの取り付け

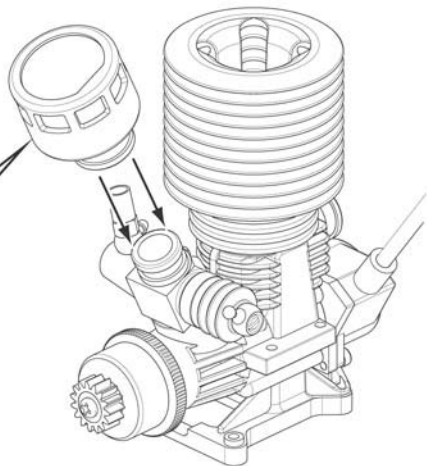
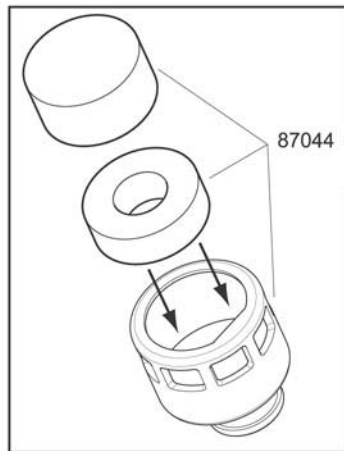

Note: Hinweis: 注意

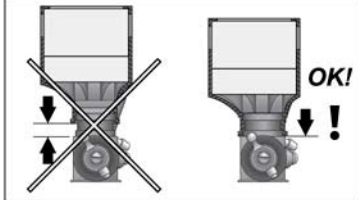

hpi-racing

hobby products international

www.hpiracing.com

HPI Racing USA
70 Icon Street
Foothill Ranch, CA 92610 USA
(949) 753-1099

www.hpiracing.co.jp

HPI Japan
3-22-20 Takaoka-Kita, Hamamatsu
Shizuoka, Japan
053-439-0833

www.hpi-europe.com

HPI Europe
Units 1-3 Queens Drive, Swadlincote,
Derbyshire, DE11 OEG, England
(44) 01283 229400