

RC8T

1:8 Scale Nitro 4WD Offroad Truggy Kit

80910: RC8T Factory Team Kit (FT)

80915: RC8T Ready -To-Run (RTR)



1:8 Scale Nitro 4WD Offroad Truggy Kit Manual

TEAM ASSOCIATED



:: Introduction

Thank you for purchasing this Team Associated product. This manual contains instructions and tips for building and maintaining your new RC8T / RC8T RTR. Please take a moment to read through it and familiarize yourself with these steps.

:: RC8T Features

:: Factory Team RC8T

- Factory assembled shocks, diffs and turnbuckles.
- Factory Team shock and diff fluids included.
- Factory Team "Big Bore" threaded, hard-coated shocks feature 16mm six hole pistons and 4mm gold shock shafts.
- Factory Team Aluminum Top Plate and Steering Rack.
- Factory Team chassis braces with integrated center stiffener.
- 4mm woven carbon fiber shock towers.
- Blue aluminum wheel hexes featuring captured drive pins and nyloc wheel nuts.
- FFC Free Float Caliper brake-system eliminates the possibility of unwanted brake drag while on throttle.
- Two-piece split-center diff mount allows quick and easy access to the center diff.
- High-Torque capacity three-shoe aluminum clutch.
- Full ball bearing drivetrain and steering.
- Factory blue titanium turnbuckles.
- True-Lock kingpin system.
- Heavy duty CVA's with captured pins.
- Woven carbon fiber radio tray.
- Durable 10mm thick suspension arms.
- Rubber rear CVA boots.
- Fully adjustable pre-drilled screw mounted wing.

:: Ready-To-Run

- Aluminum wheel nuts
- Tough, steel turnbuckles
- True-Lock kingpin system
- Heavy duty CVA's with captured pins
- Hard coated shock bodies with 4mm shock shafts and rubber boots
- Durable, molded radio tray & antenna mount
- Sealed radio box
- 3mm aluminum front/rear shock towers
- Durable 10mm thick suspension arms
- Rubber CVA boots
- Fully adjustable pre-drilled screw mounted wing
- Strong anti-wobble wheels
- Anti-foaming fuel tank
- Low-profile, elliptical, high-flow two-stage air filter

:: Additional

:: Factory Team

Your RC8T Truggy comes with all the Factory Team hopups. However, there are some items you will need to complete your kit:

- .21 Class Rear Exhaust Engine
- 2 Channel Radio Set - FM/PCM recommended.
- 4.8v-6.0v Receiver Battery Pack (RC8T will accept either flat or hump pack, AE Part #613 Flat, 612 Hump)
- Muffler, Joining Pack or Manifold & Spring
- AA-Size Batteries for Transmitter (x8)
- Model Car Fuel (30% Nitro recommended)
- Fuel Bottle (AE Part #1749)
- Glow Starter (AE Part #1738)
- Starter Box (AE Part #1750)
- 1/8th Scale Truggy Tires
- FT Tire Glue (AE Part #1597)
- Thread Lock Compound (AE Part#1596)
- Lexan Specific Spray Paint
- FT Body Scissors (AE Part#1737)
- Reamer/Hole Punch
- FT Hex Driver Set (AE Part #1541)
- Hobby Knife
- Needle Nose Pliers
- Wire Cutters

:: Ready-To-Run

Your RC8T RTR Truggy comes factory assembled including radio gear. However, there are some items you will need to complete your kit:

- AA-Size Batteries for Transmitter (x8)
- AA-Size Batteries for the onboard electronics (x4) (or a 4.8v-6.0v Receiver Battery Pack, 3x2 pack recommended, AE Part #613 Flat, 612 Hump)
- D-Size Battery for Glow Starter (x1)
- 6-Cell Sub-C Size Battery Pack for Pro-Start Starting Gun, AE Part #695
- Charger for Battery Pack
- Model Car Fuel (20%-30% Nitro recommended)

:: RC8T FT Only Notes

Your RC8T FT Truggy comes with pre-built Diffs, Turnbuckles, and Shocks. The manual goes through the complete build of the kit for your future reference and maintenance.
 Page 4: **Fill** the front and rear differentials with 7000cst diff fluid
 Page 5: **Fill** the center differential with 7000cst diff fluid
 Page 7-8: **Fill** pre-assembled shocks with shock oil.
 You can now continue on to build the rest of your new Team Associated FT RC8T Kit!

:: Front and Rear Differentials

Bag A2/A3

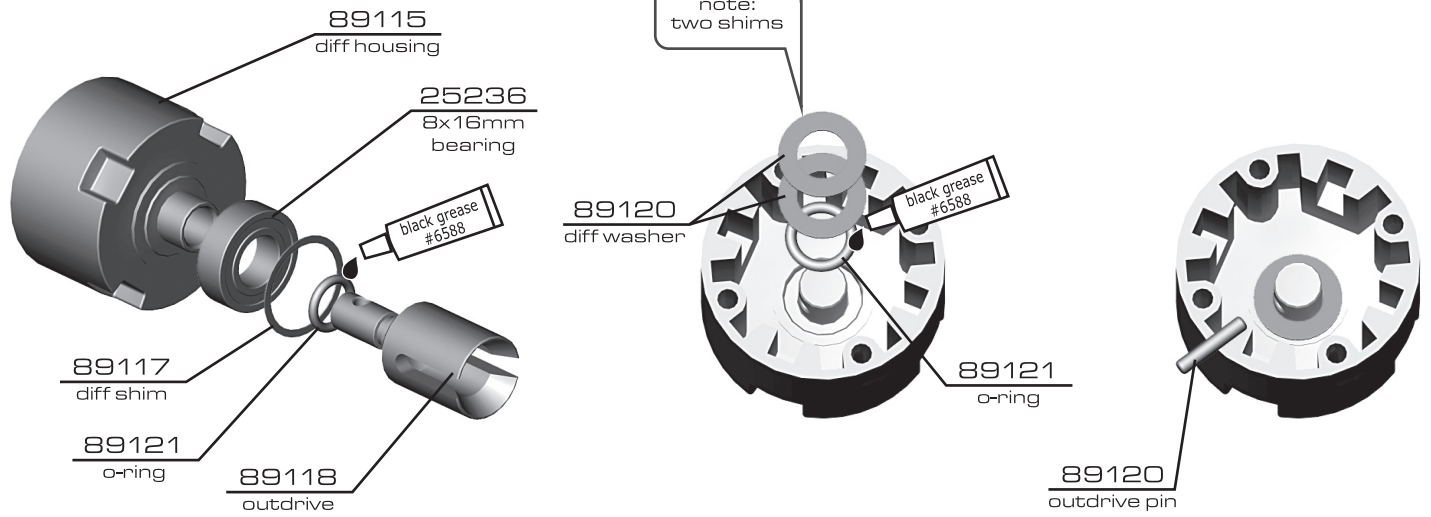

:: Front and Rear Differentials (cont.)

Bag A2/A3



:: Front and Rear Differentials (cont.)

Bag A2/A3

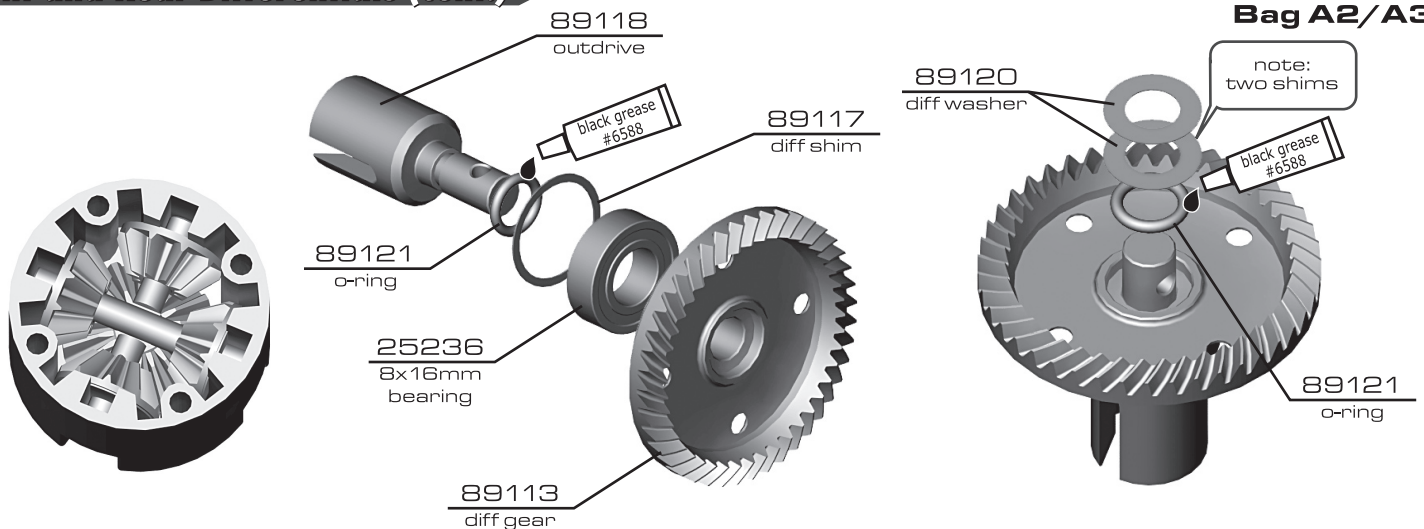

:: Front and Rear Differentials (cont.)

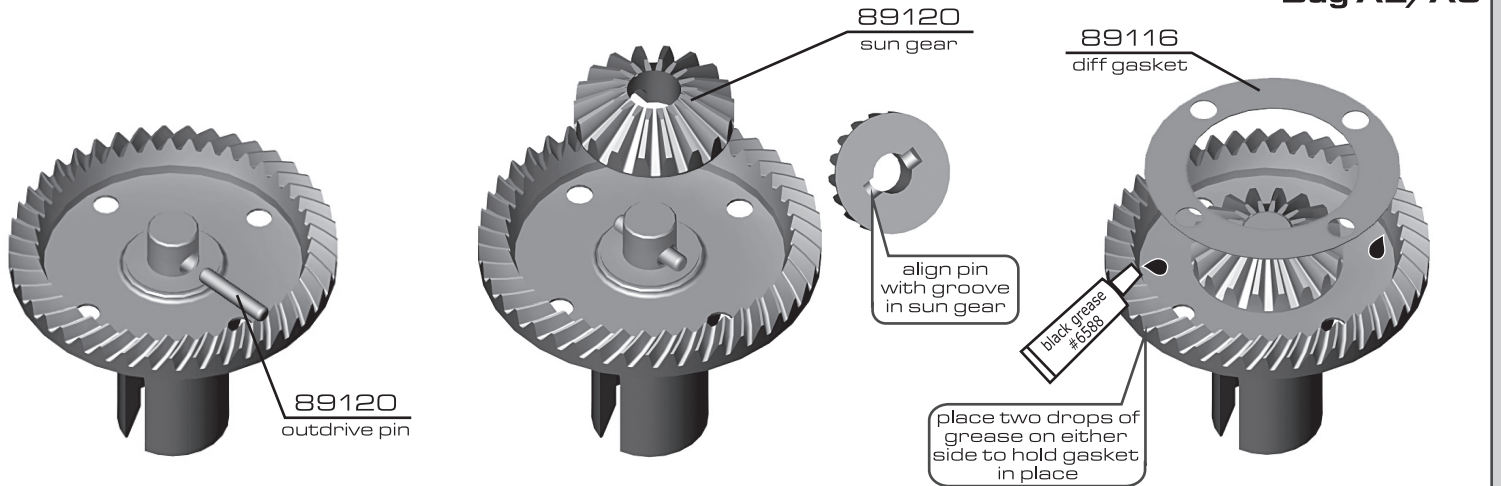

:: Front and Rear Differentials (cont.)

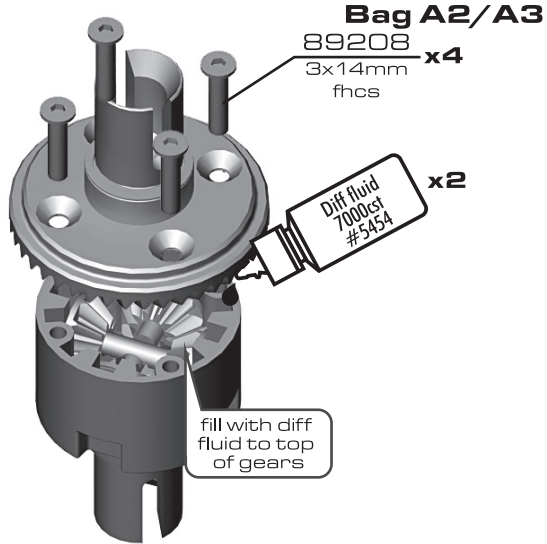

:: Center Differential

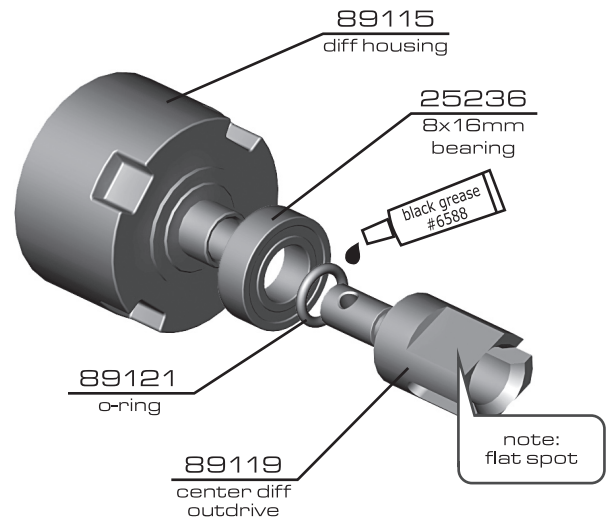

:: Center Differential (cont.)

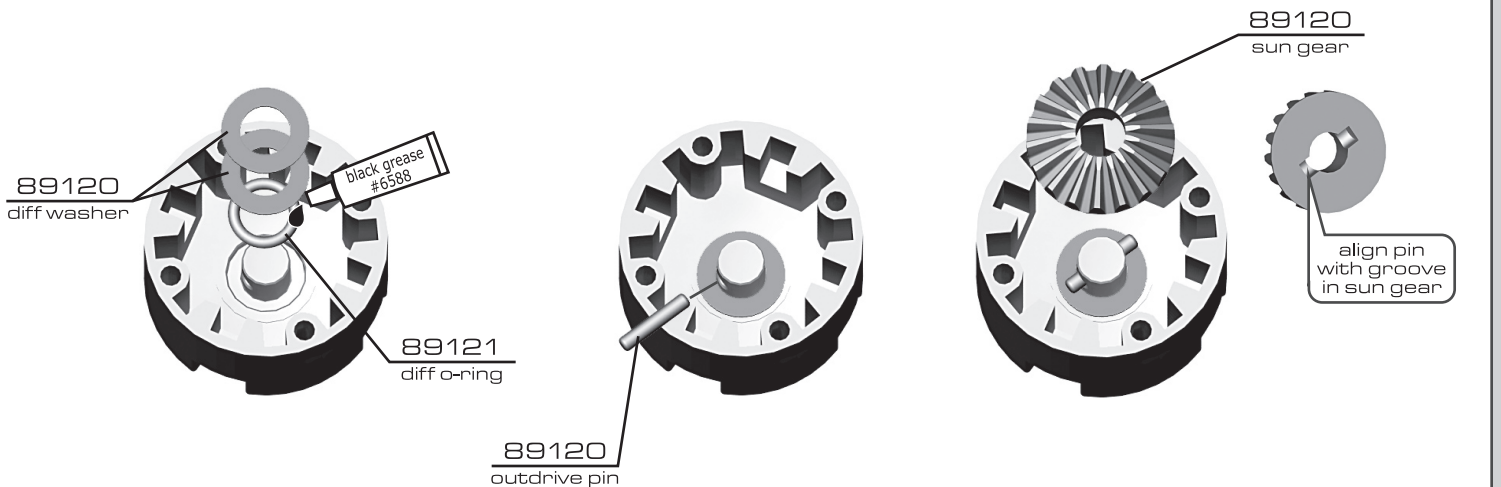

:: Center Differential (cont.)

Bag A1



89120
spider gear
assembly

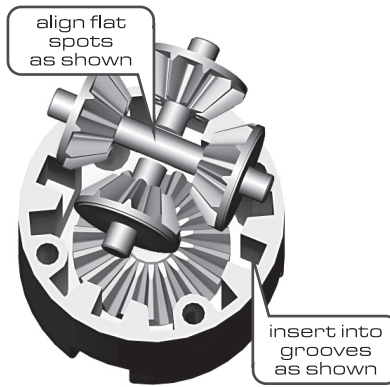

:: Center Differential (cont.)

Bag A1

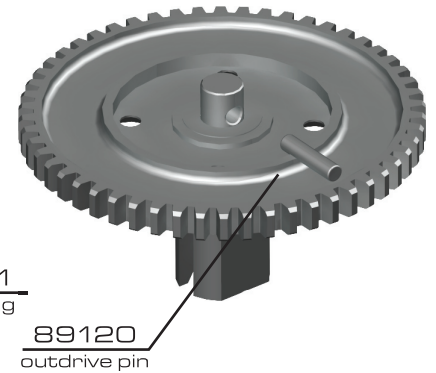
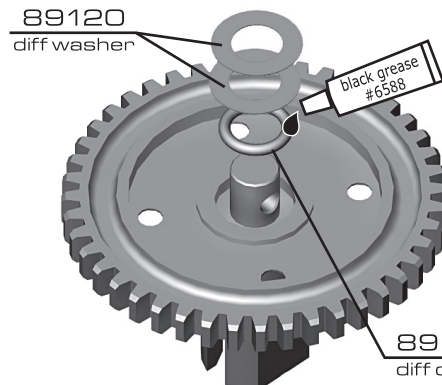
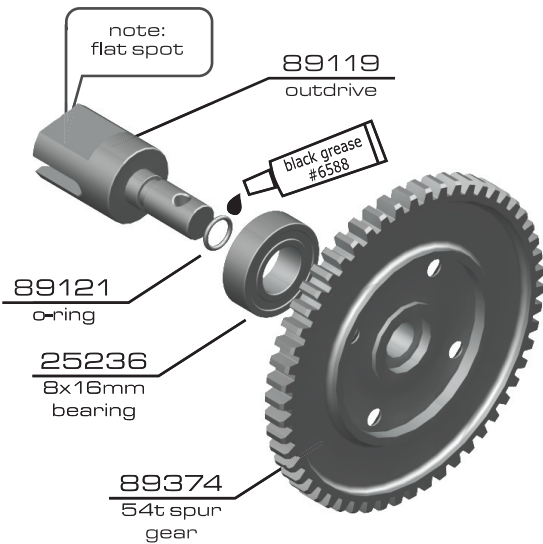

:: Center Differential (cont.)

Bag A1

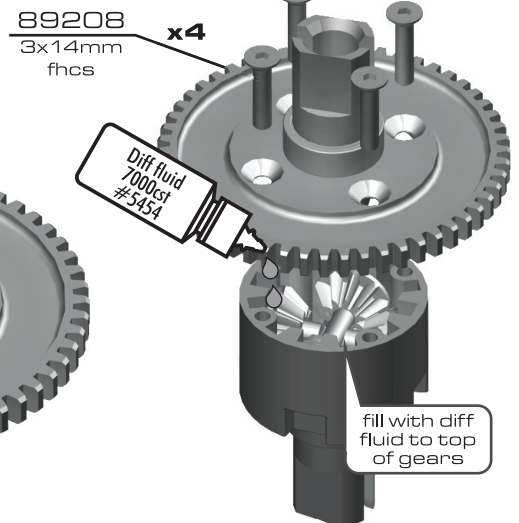
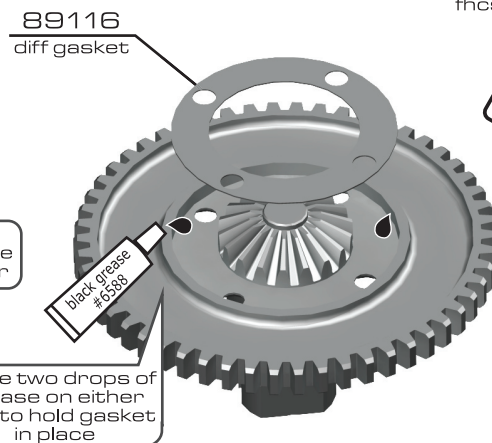
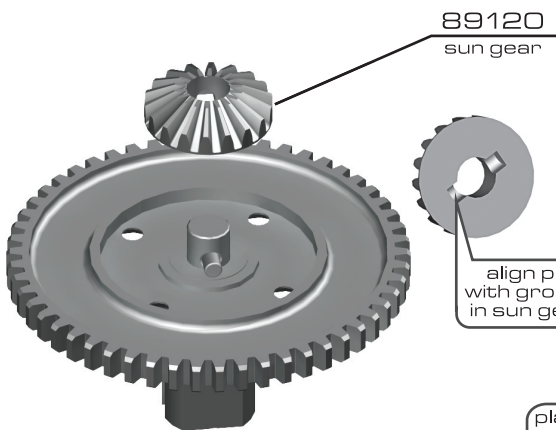

:: Chassis Braces

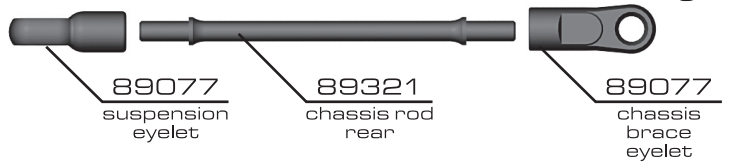
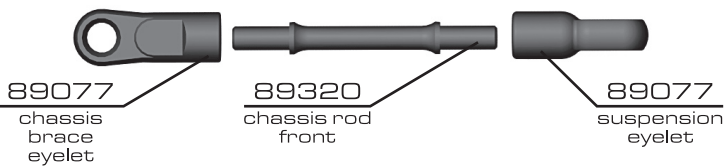

Bag B

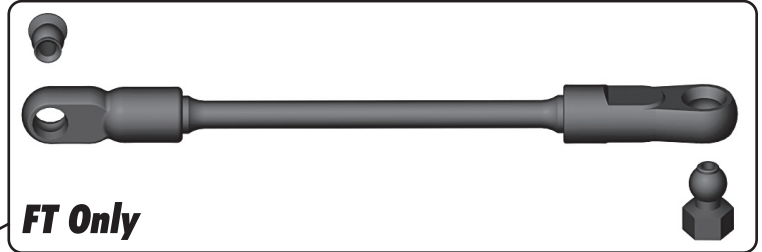
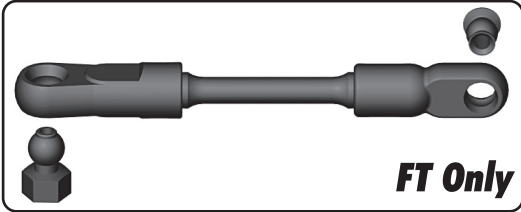

89320 front chassis brace set

89321 rear chassis brace set

:: Steering Turnbuckles

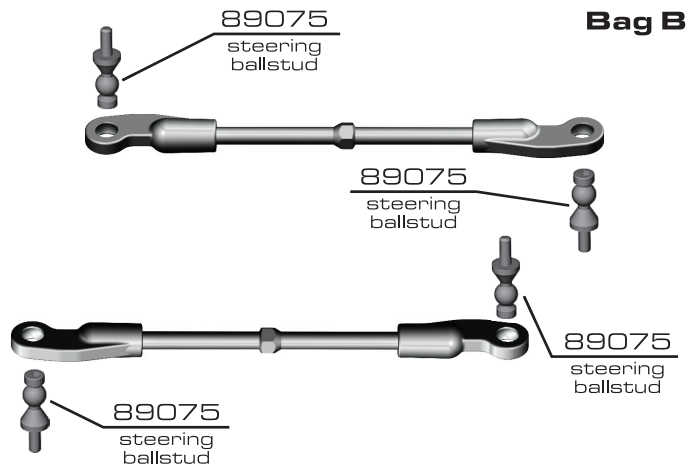
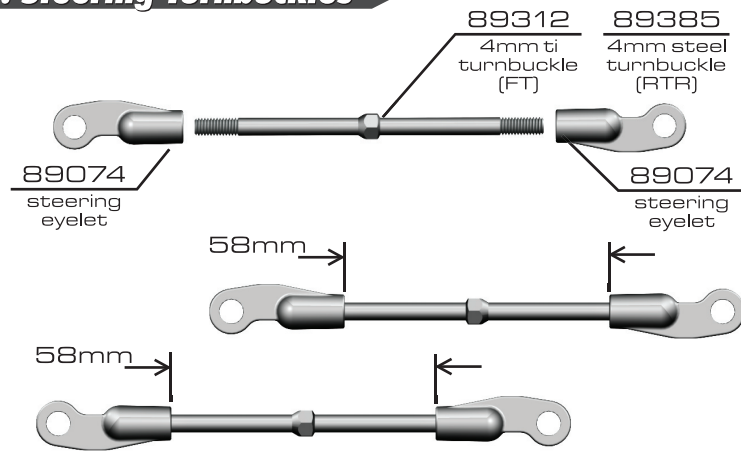

Bag B

:: Servo Turnbuckle

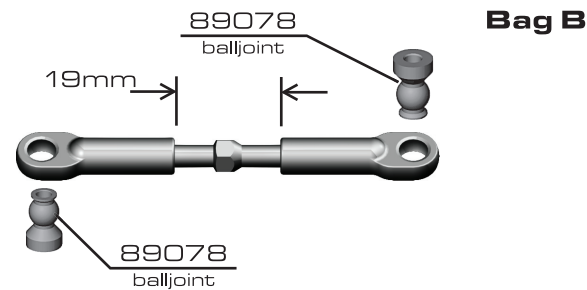
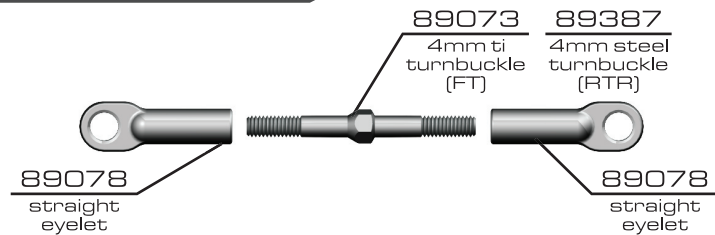

Bag B

:: Camber Turnbuckles

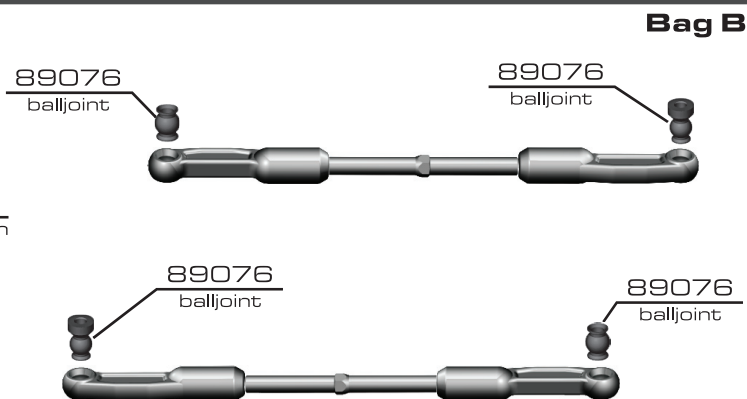
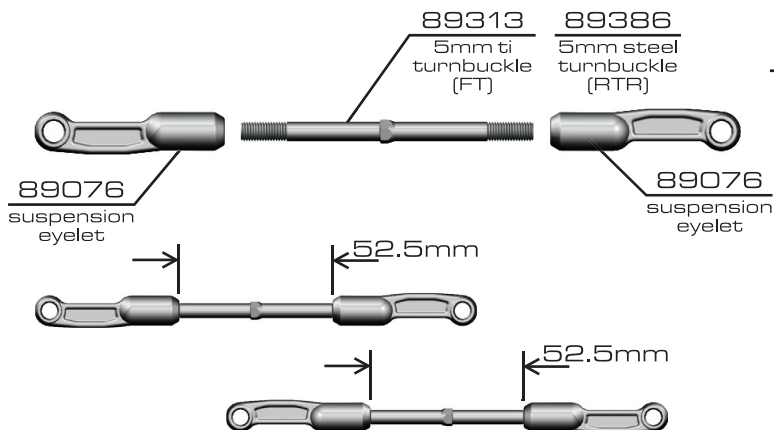

Bag B

:: Shocks

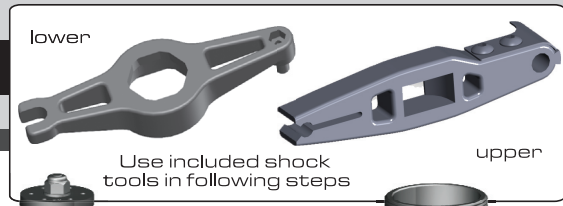

- 89215 piston locknut
- 89278 piston washer
- 89353 shock piston set (1.3, blank)
- 89337 shock shaft gold, front (FT)
- 89384 shock shaft front (RTR)
- 1.3mm piston
- 89054 shock shaft gold, rear (FT)
- 89261 shock shaft rear (RTR)
- 89336 shock body front (FT)
- 89392 molded shock body front (RTR)



- 89344 shock body rear (FT)
- 89393 molded shock body rear (RTR)
- 89066 shock o-rings
- 89352 spacer
- 89352 o-ring
- 89352 bottom nut

Bag C

:: Shocks (cont.)

- 89356 shock boot front
- 89357 shock boot rear
- fit boot into groove

- 89352 shock boot washer
- 89065 shock rod eyelet
- tighten eyelet to line on shaft

- 89065 shock rod eyelet ball



Bag C

:: Shocks (cont.)

Bladder installation

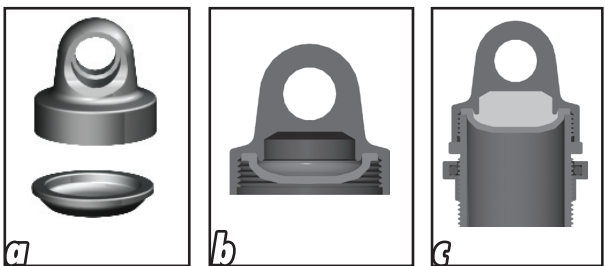

As you install the cap with bladder, it will force out any extra oil. If you install the cap with the shaft fully extended, you are running FULL REBOUND.
To run less rebound, unthread the cap 1-2 turns and compress the shaft to the desired position and re-tighten the cap.

use upper tool on cap

- 89335 shock cap (FT)
- 89351 shock bladder (FT)

- 89394 molded shock cap (RTR)
- 89394 molded shock cap o-ring (RTR)



*some residual oil may appear for your first few runs around the shock cap as a result of bleeding.

- 89352 threaded shock collar o-ring (FT)



- 89355 threaded shock collar (FT)

*The RTR shocks use the molded shock cap and o-ring. To bleed the shocks, fill them with oil and install the cap. Loosen the cap a half turn (with the shock shaft fully extended) and pump out a small amount of oil by pushing the shaft in. Retighten the cap.

Bag C

:: Shocks (cont.)

Bag C

RTR

89396 shock spring retainers

89340 shock spring front silver (5.1 lbs)

89348 shock spring rear silver (3.3 lbs)

89354 spring cup

-slide boot over shock eyelet

-install spring cup over boot and eyelet

front: 3mm
rear: 9mm

1 mm
2 mm
3 mm
5 mm
10 mm

89396 pre-load clips

:: Steering

FT Only

89039 hinge pin bushing (2 dot down)

89236 top plate (upper)

89211 3x26mm fhcs

25215 M3 locknut

hinge pin bushings
2 dot down

threadlock #1596

RTR Only

89010 top plate (lower)

89211 3x26mm fhcs

89451 front chassis brace RTR

25203 3x12mm fhcs x5

89010 top plate (upper)

25215 M3 locknut

89039 hinge pin bushing (2 dot down)

89039 hinge pin bushing (2 dot down)

25215 M3 locknut x4

:: Steering (cont.)

Bag D2

31404 6x10mm bearing

89016 servo saver bolt

89015 servo saver arm

black grease #6588

89015 servo saver bellcrank

89016 servo saver spring

89016 servo saver retainer

gap setting 8.3mm

threadlock #1596

:: Steering (cont.)

Bag D3

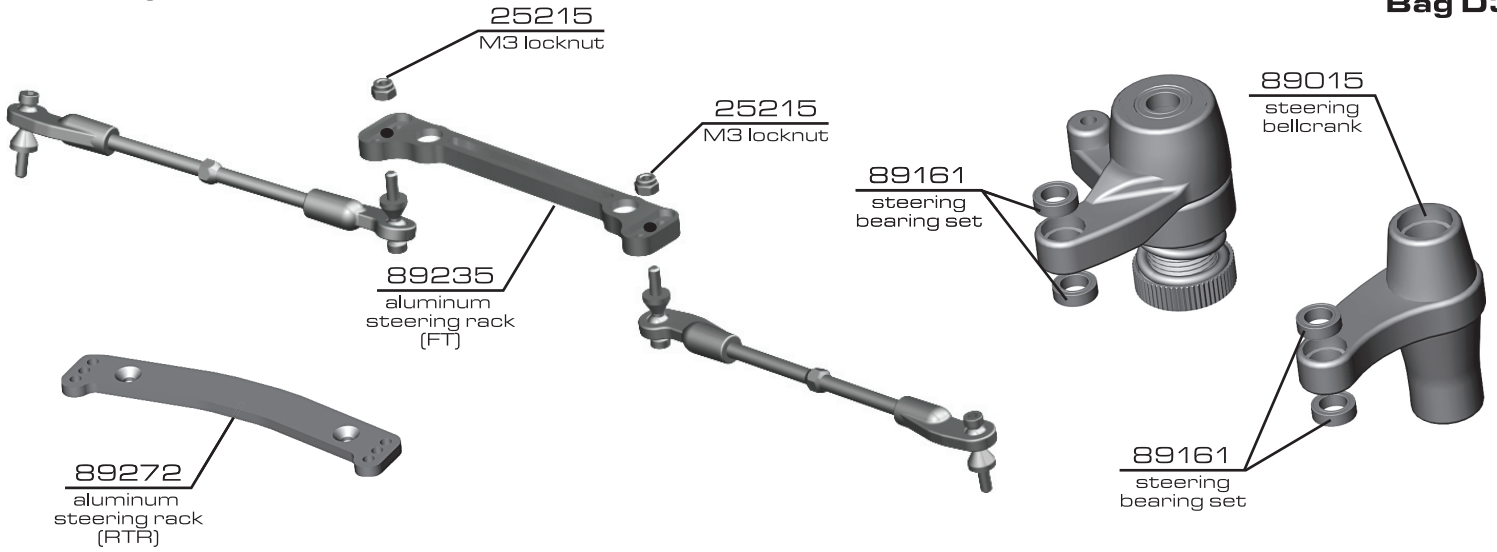

:: Steering (cont.)

Bag D3

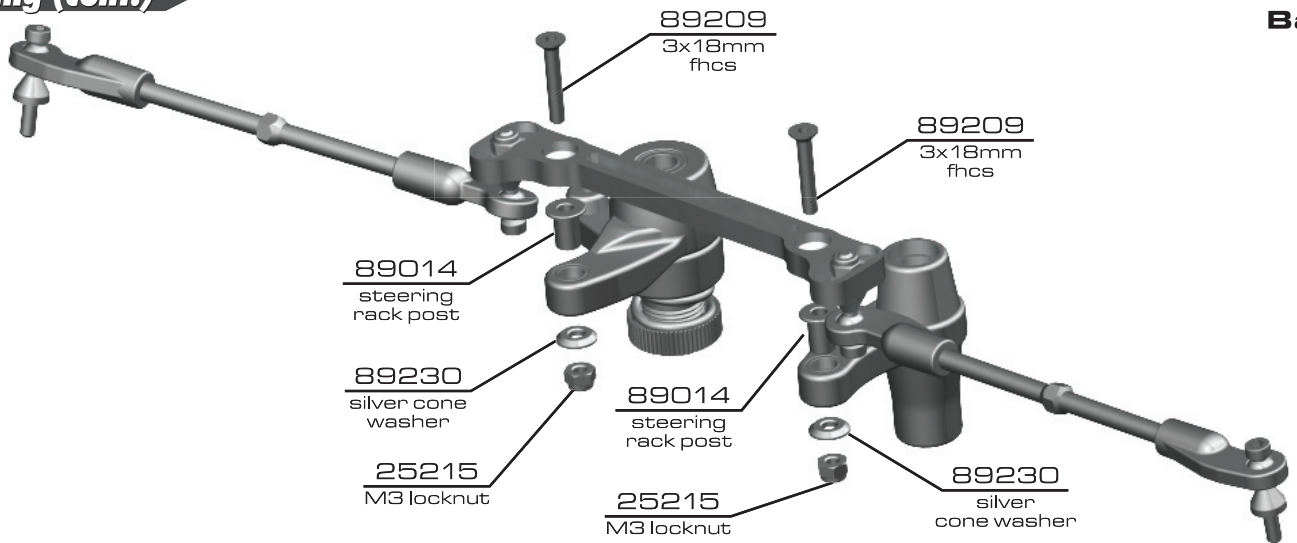

:: Steering (cont.)

Bag D3

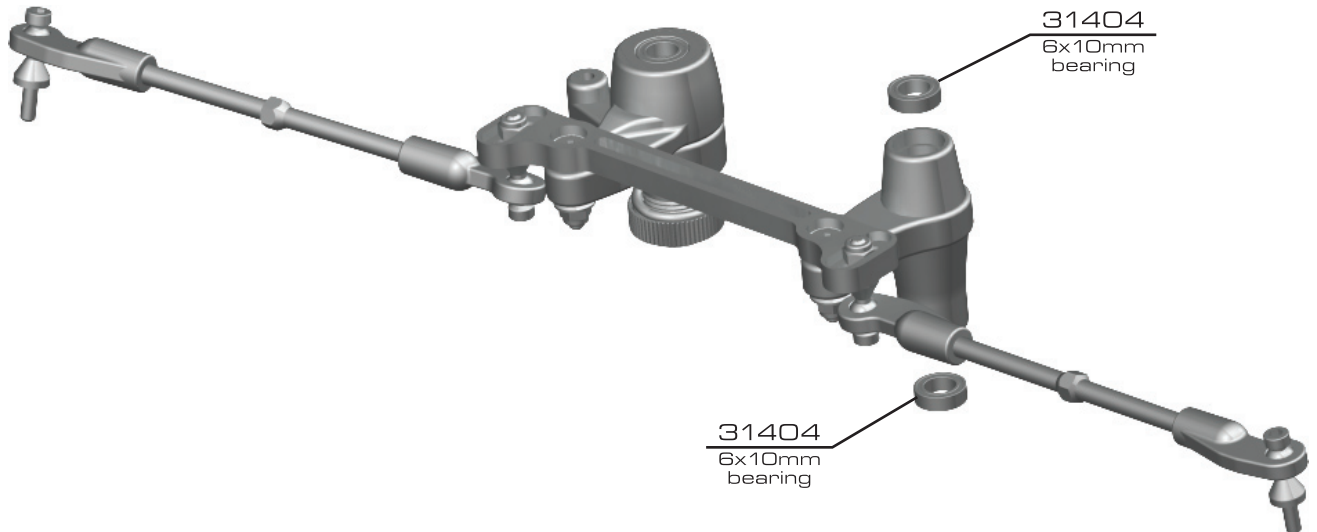

:: Steering (cont.)

Bag D3

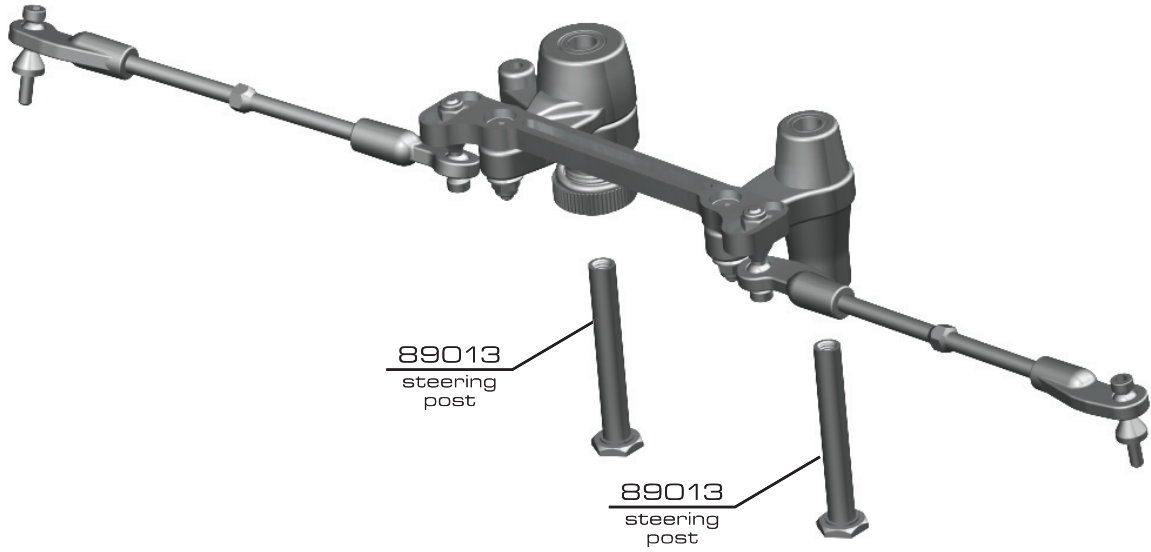

:: Steering (cont.)

Bag D3

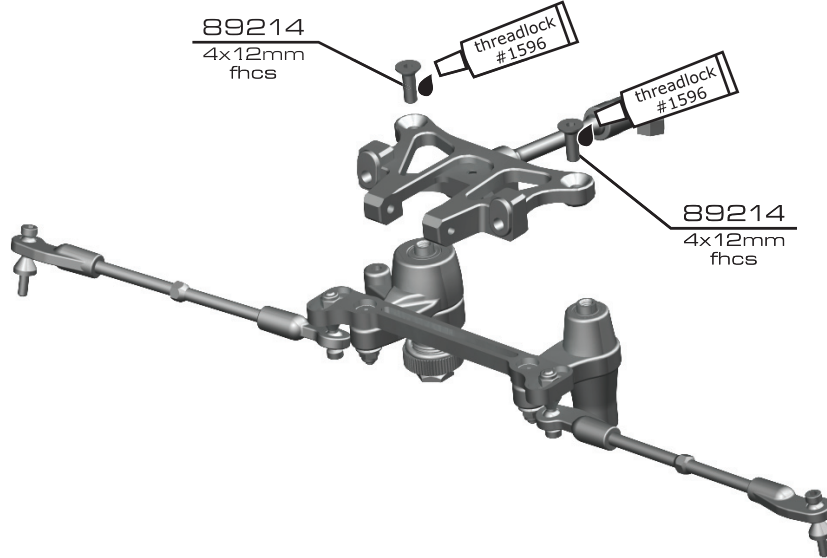

:: Front Gearbox

Bag E1

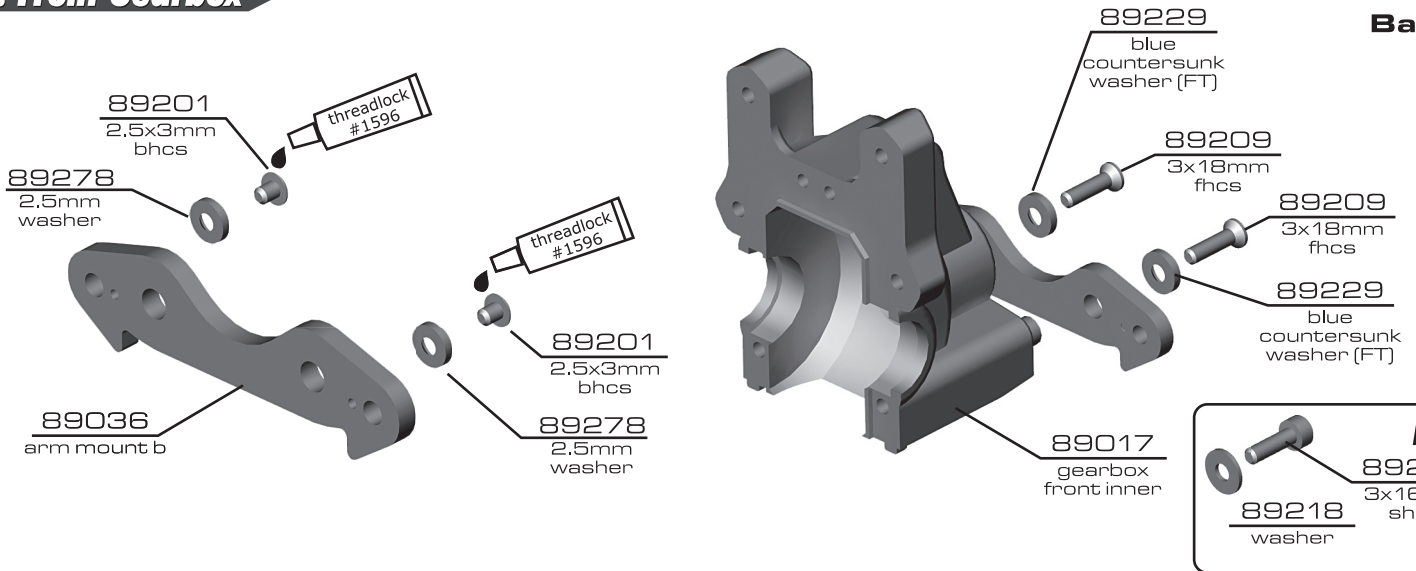

:: Front Gearbox (cont.)

Bag E2

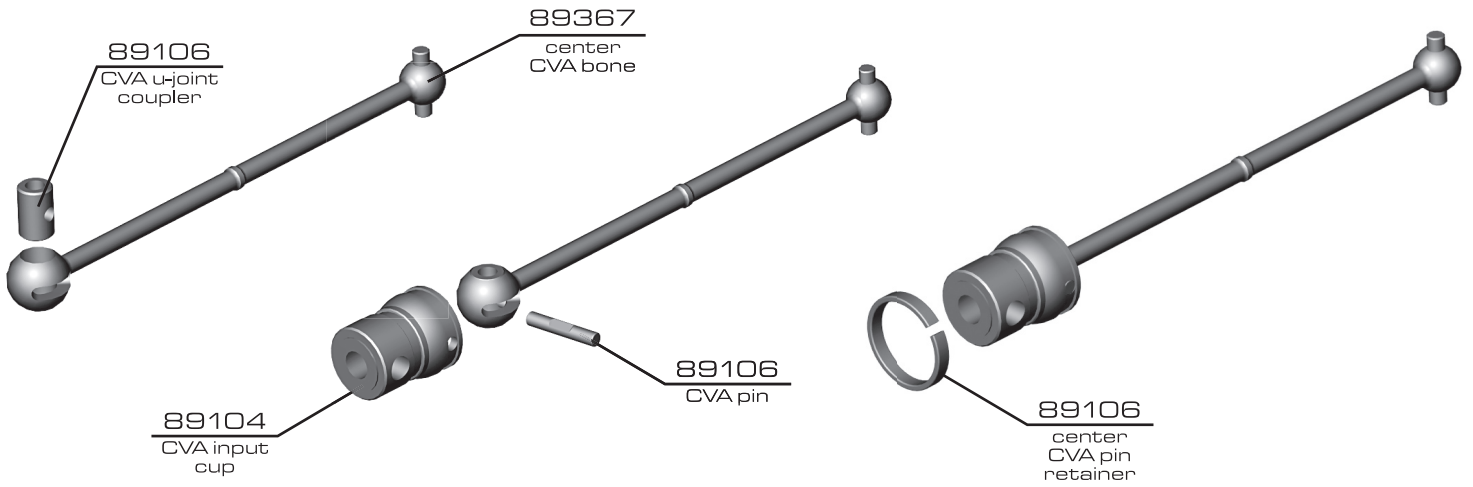

:: Front Gearbox (cont.)

Bag E2

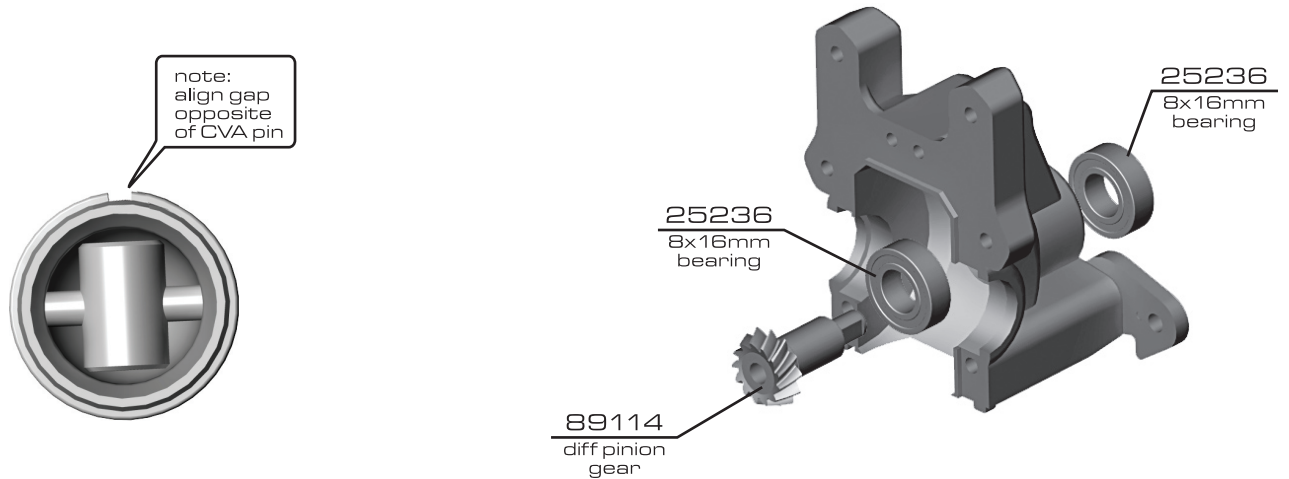

:: Front Gearbox (cont.)

Bag E2

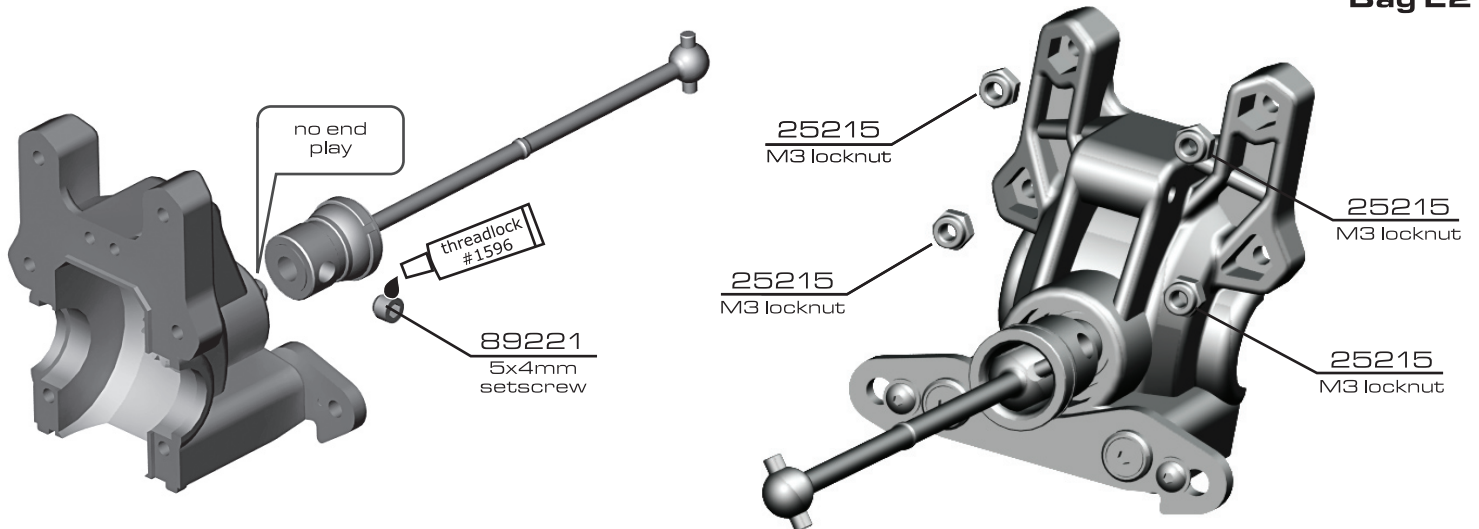

:: Front Gearbox (cont.)

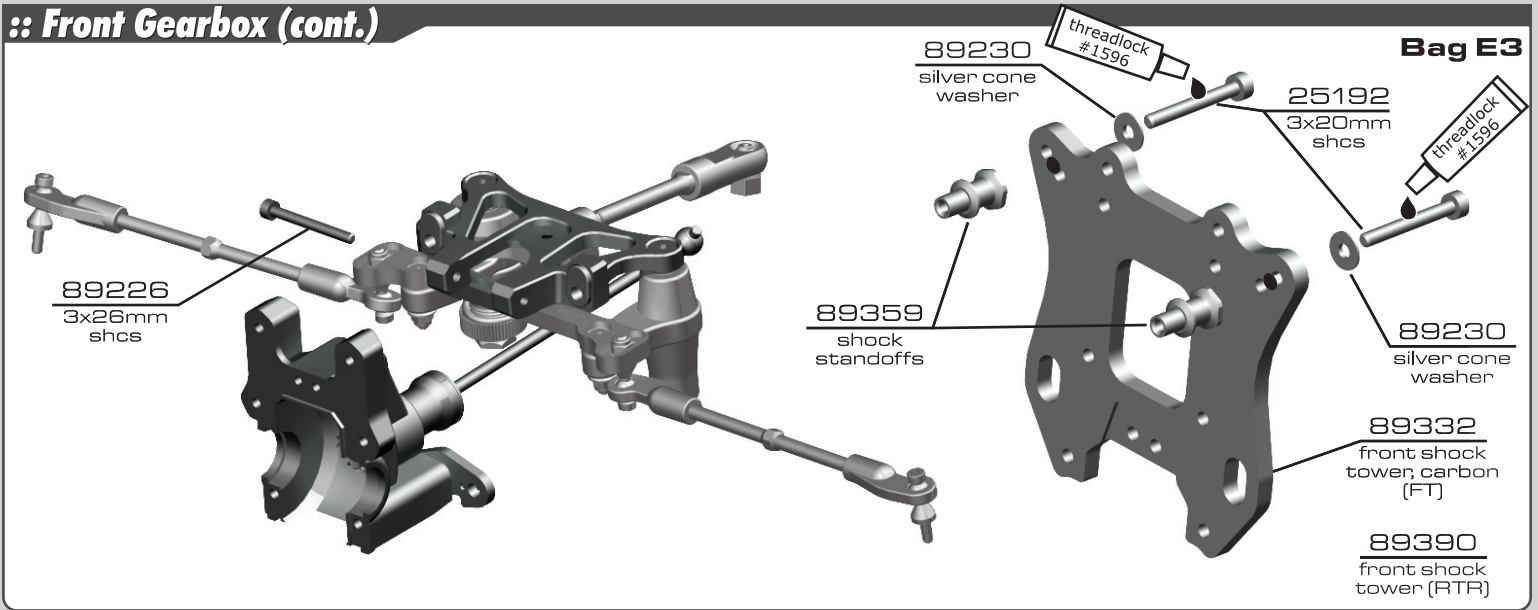

:: Front Gearbox (cont.)

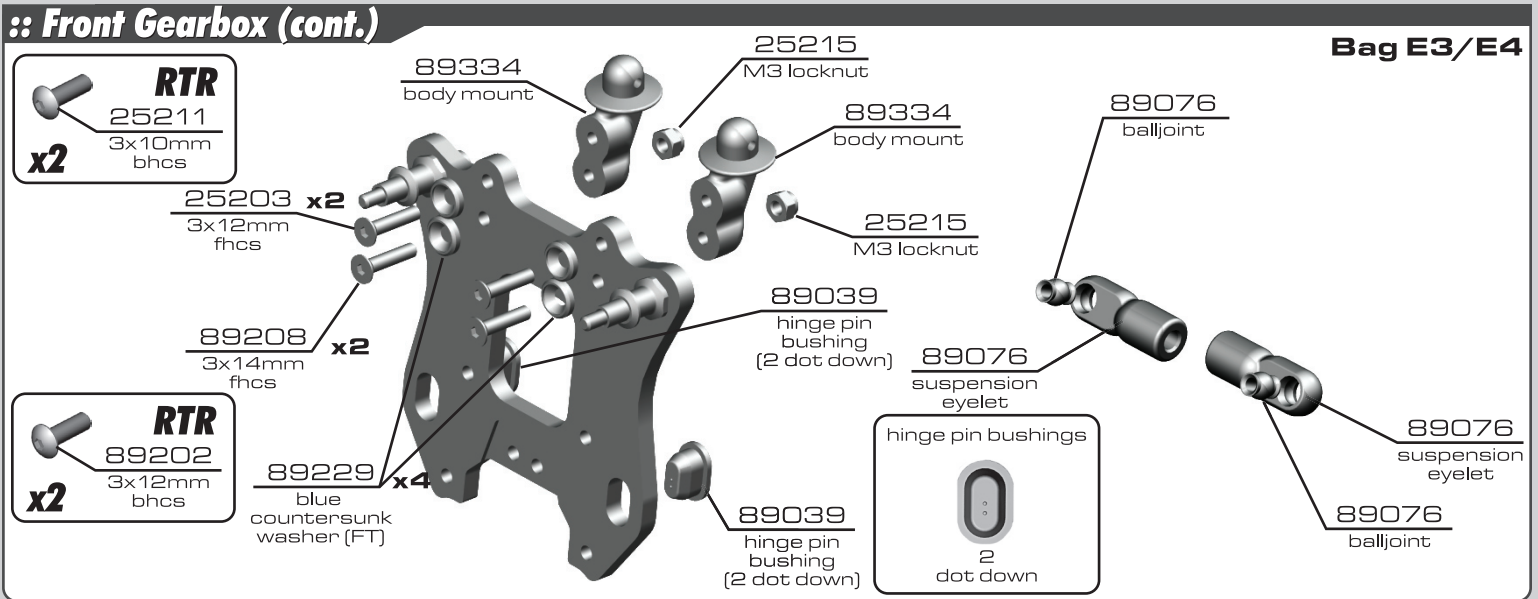

:: Front Gearbox (cont.)

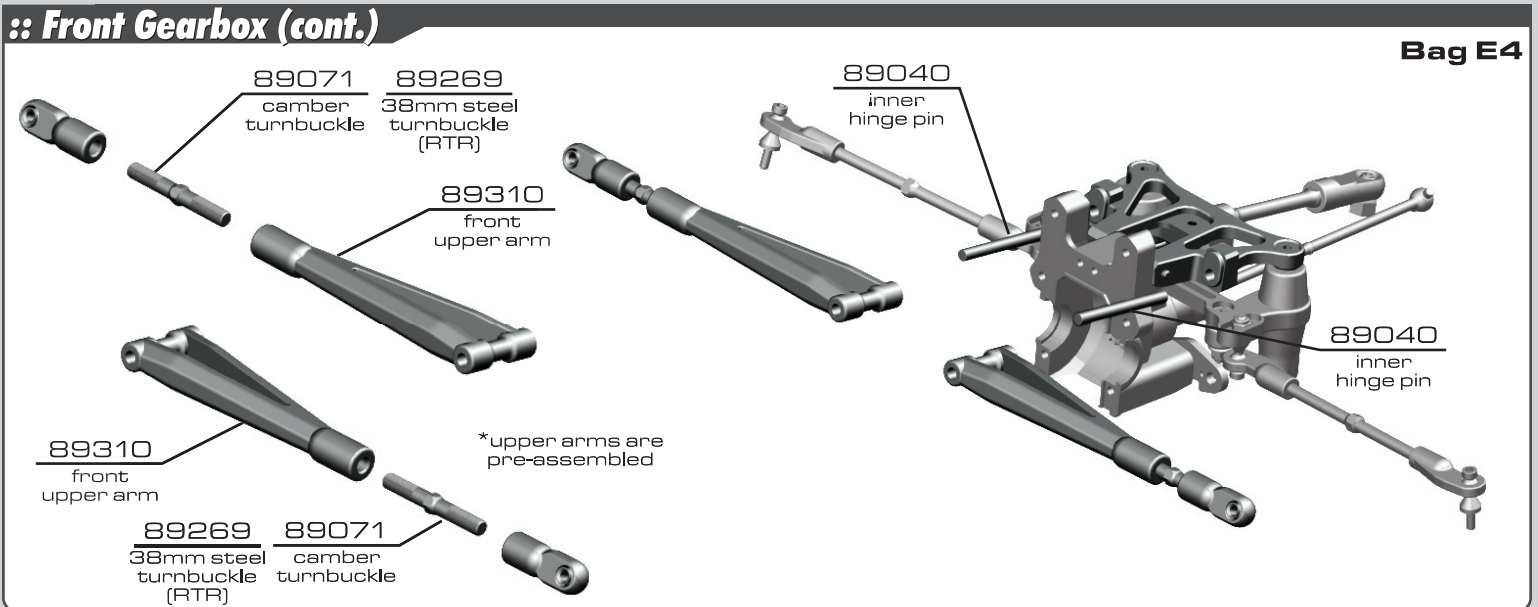

:: Front Gearbox (cont.)

Bag E3/E4

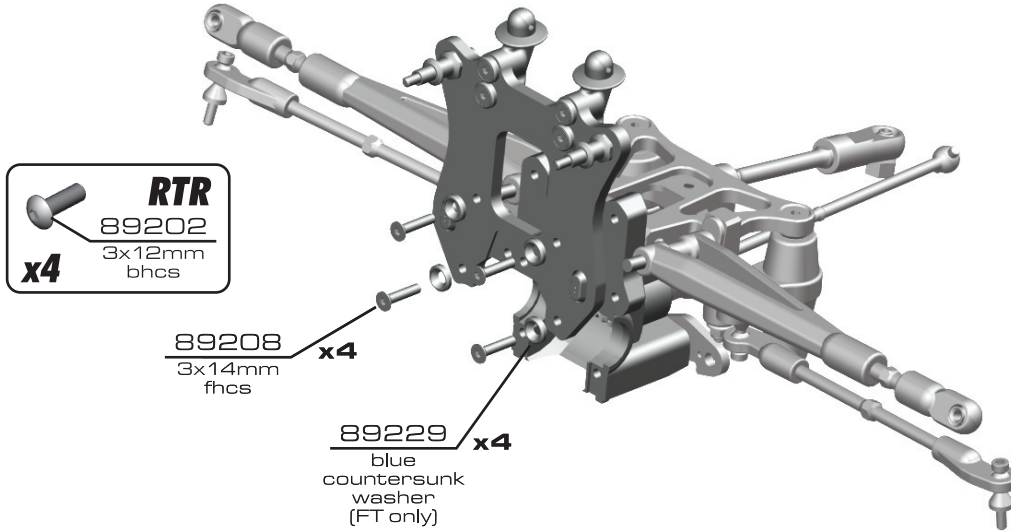

:: Front Gearbox (cont.)

Bag E4

!
*remember to install the
diff shims between the
diff casing and bearings
before inserting diff into
the gearbox

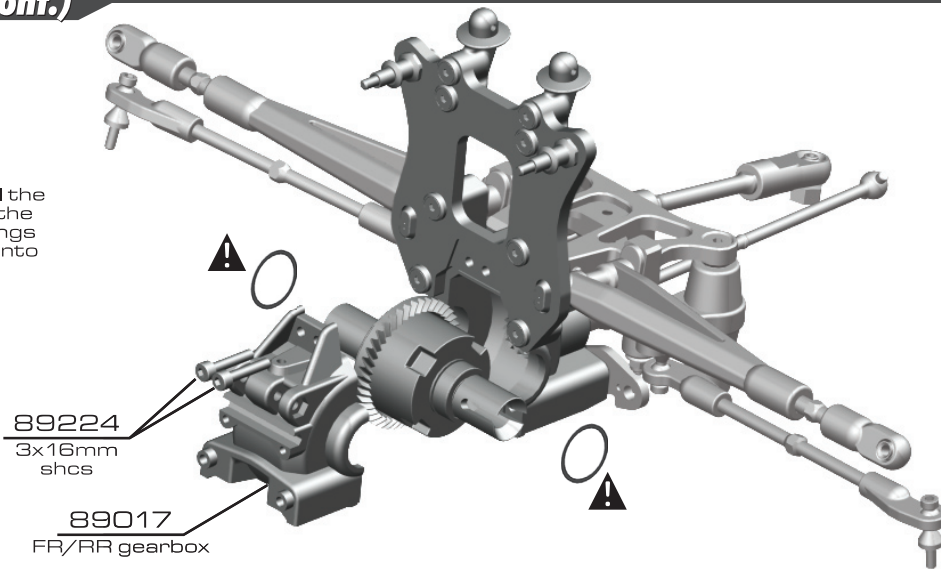

:: Suspension

Bag F1

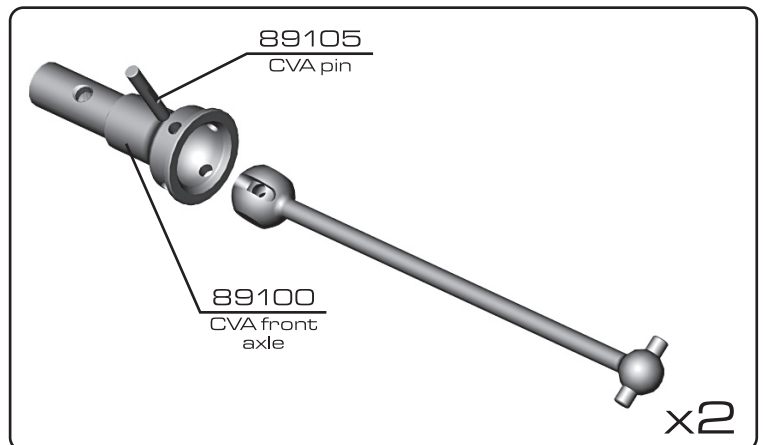
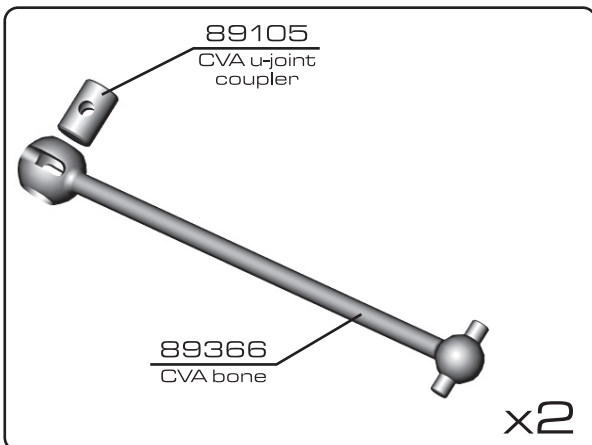

:: Suspension (cont.)

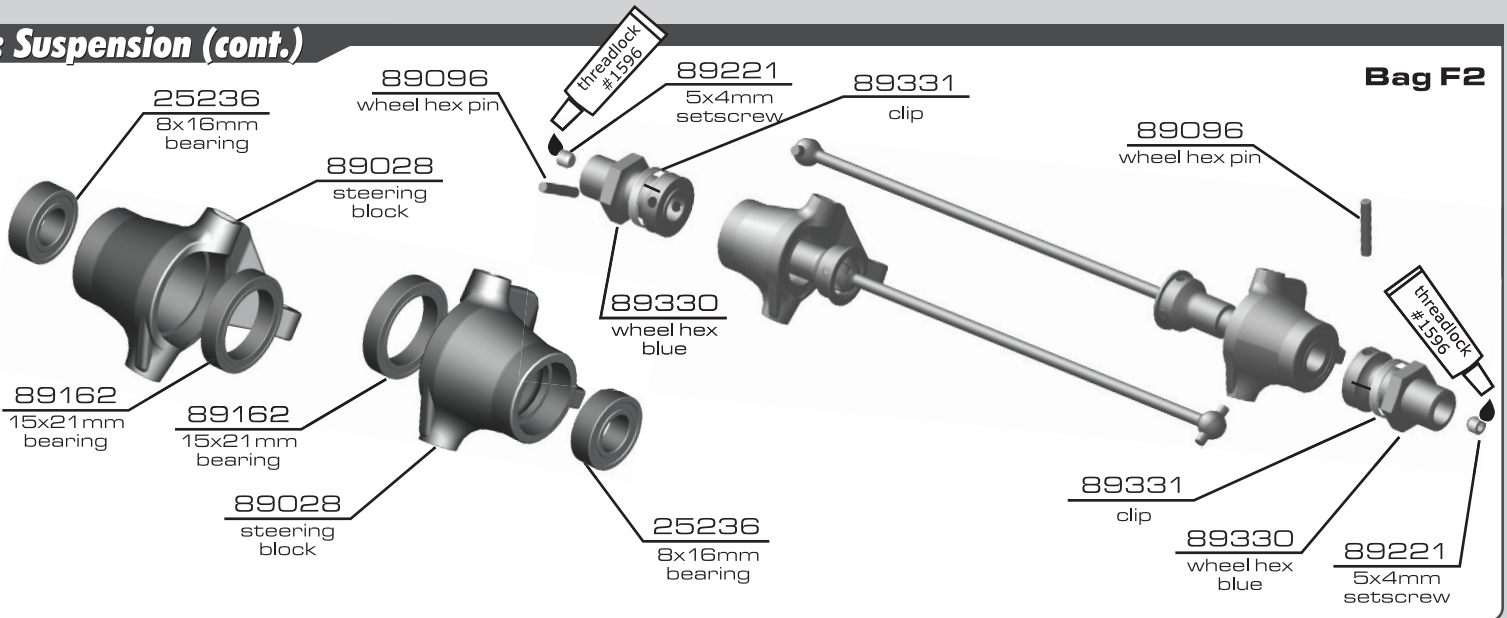

:: Suspension (cont.)

*cut-away view

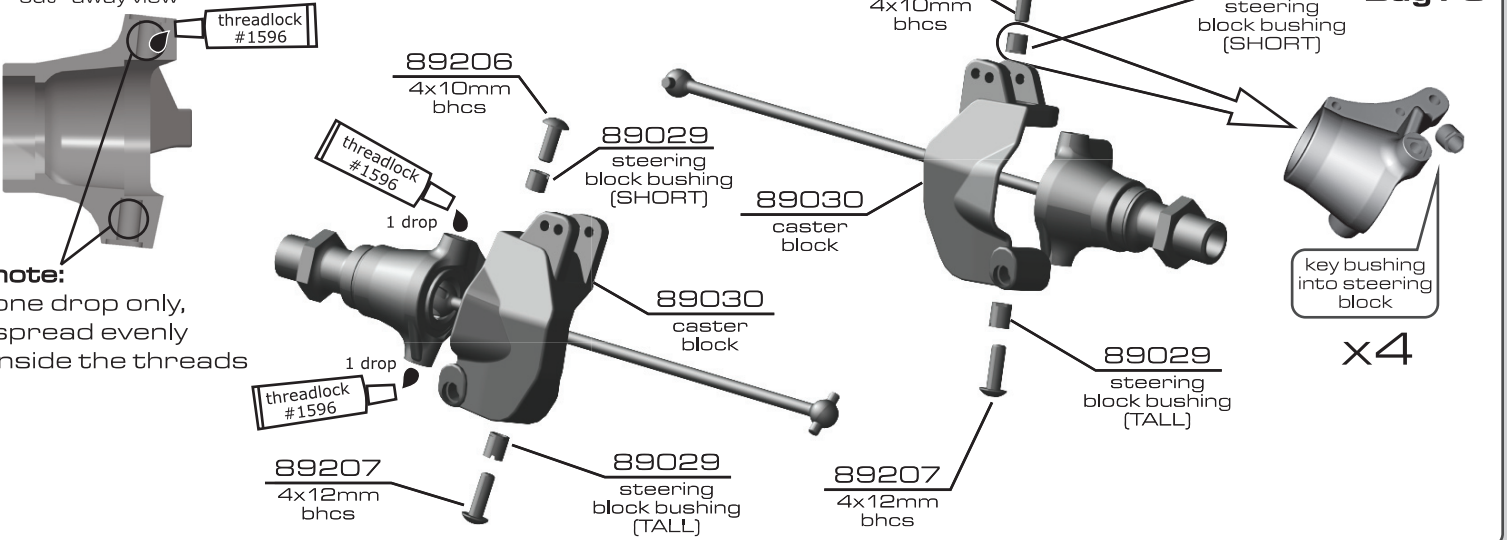

:: Suspension (cont.)

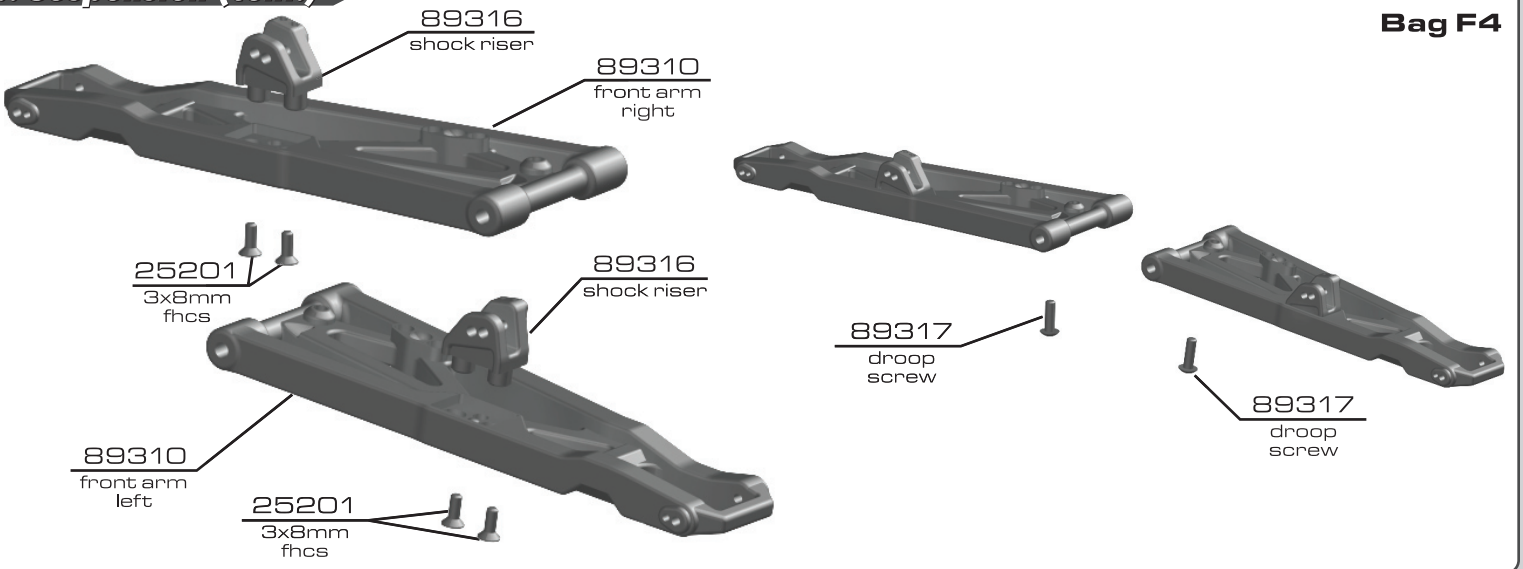

:: Suspension (cont.)

Bag F4

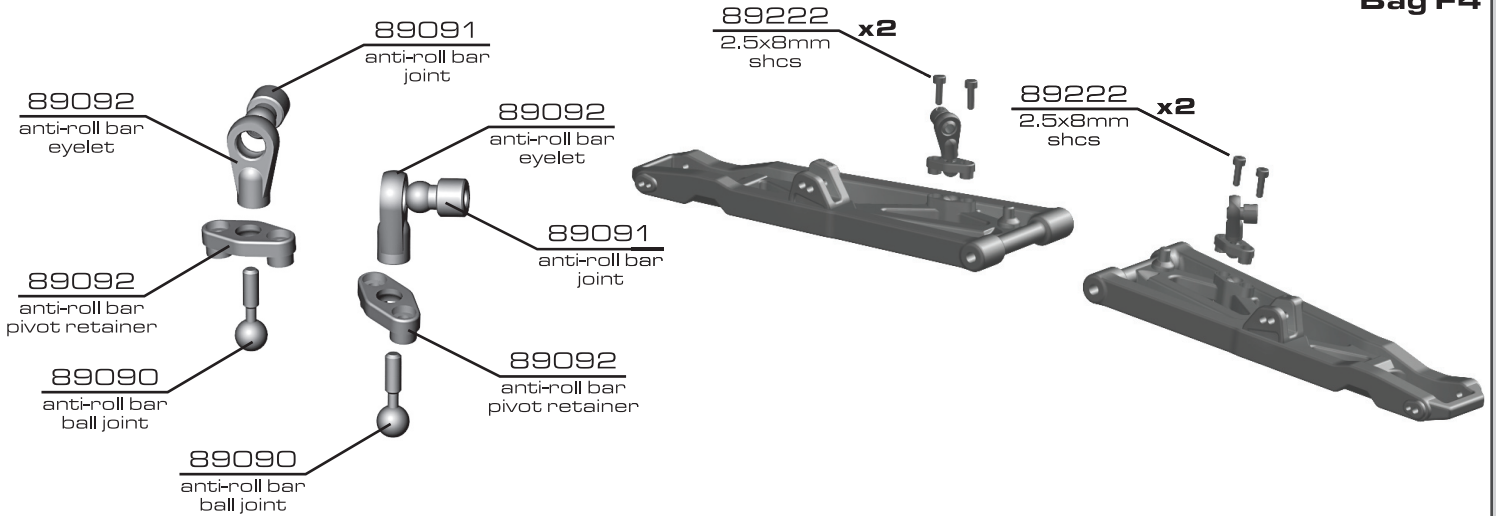

:: Suspension (cont.)

Bag F5

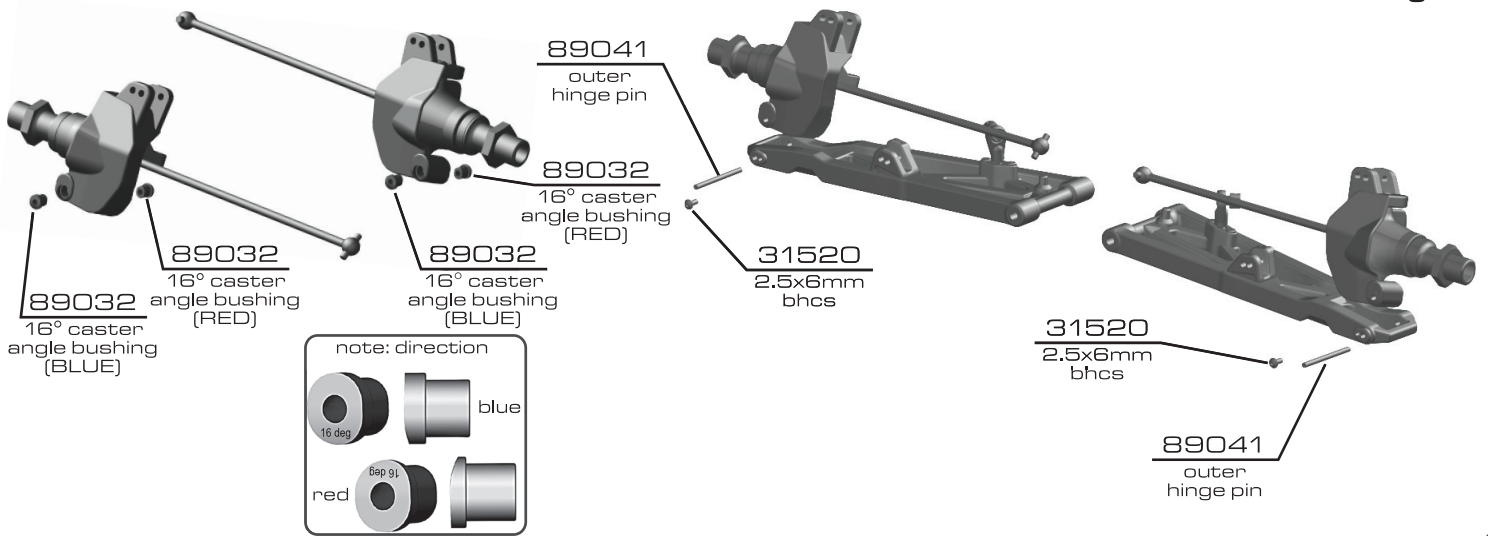

:: Suspension (cont.)

Bag F5

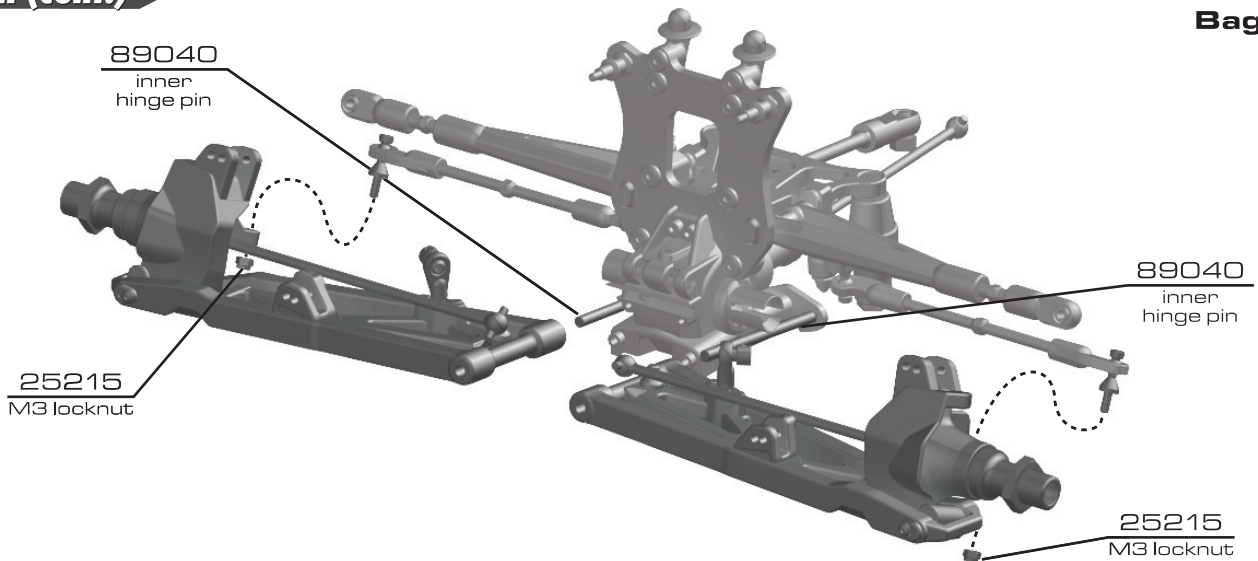

:: Suspension (cont.)

Bag F5

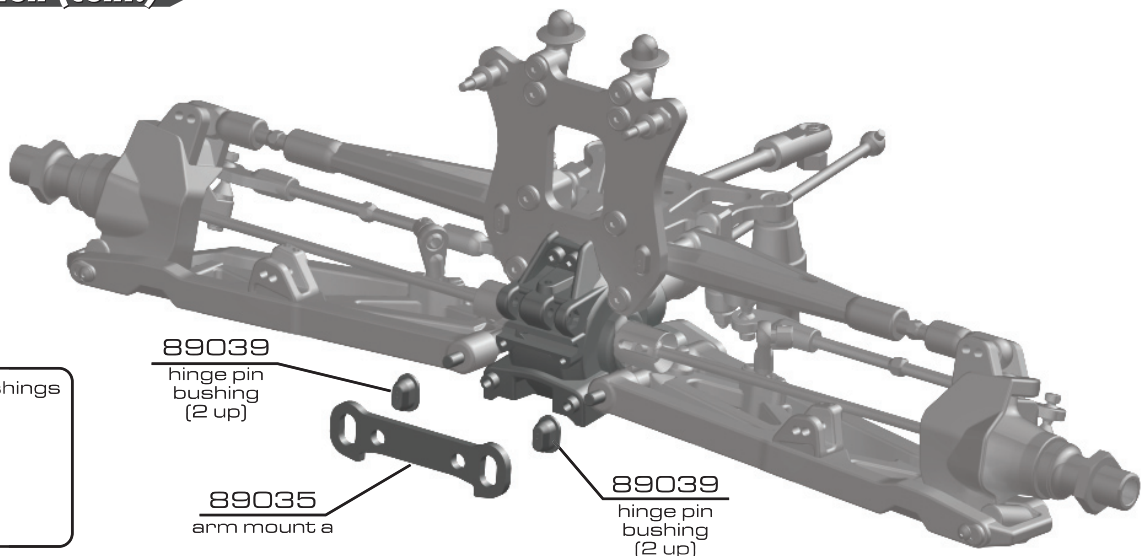
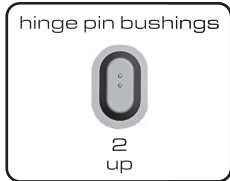

89039
hinge pin
bushing
(2 up)

89035
arm mount a

89039
hinge pin
bushing
(2 up)

:: Suspension (cont.)

Bag F5

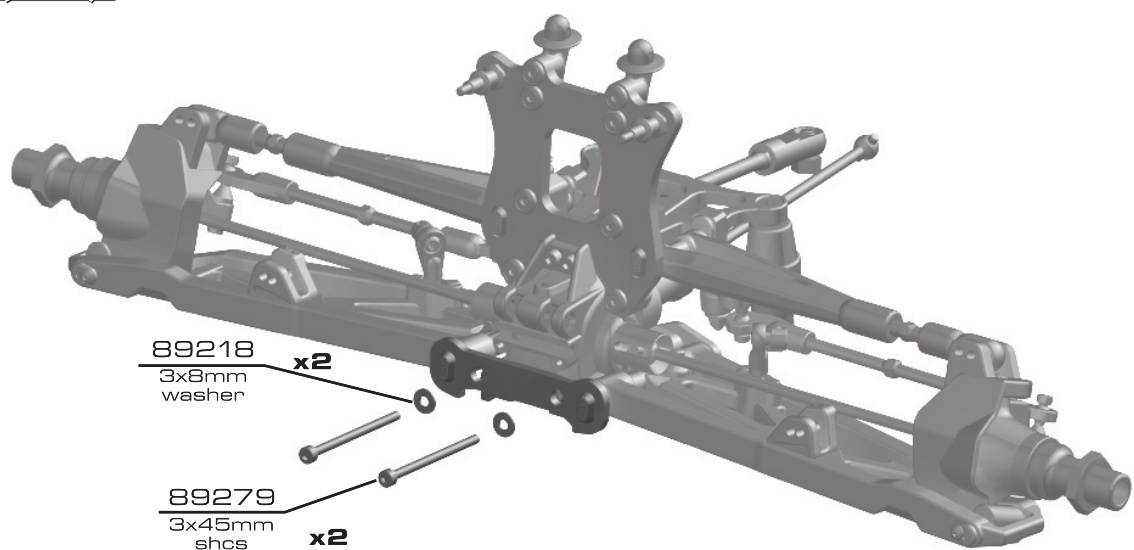

89218 **x2**
3x8mm
washer

89279 **x2**
3x45mm
shcs

:: Suspension (cont.)

Bag F5

89031 **x2**
blue 1.7mm
caster
spacer

25215
M3
locknut

89204
3x24mm
bhcs



89031 **x2**
blue 1.7mm
caster
spacer

25215
M3 locknut

89204
3x24mm
bhcs

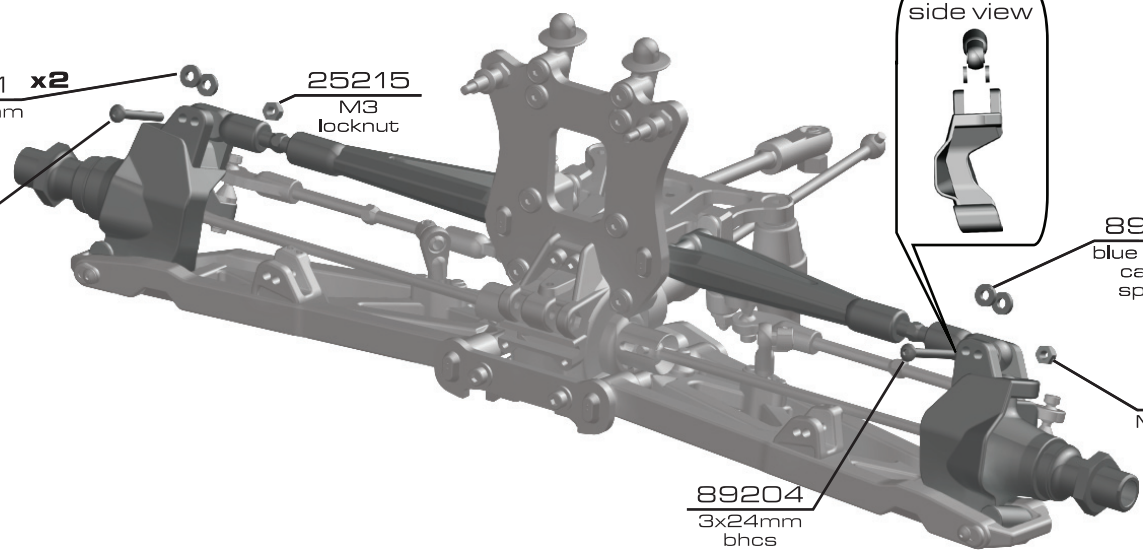

:: Suspension (cont.)

Bag F6

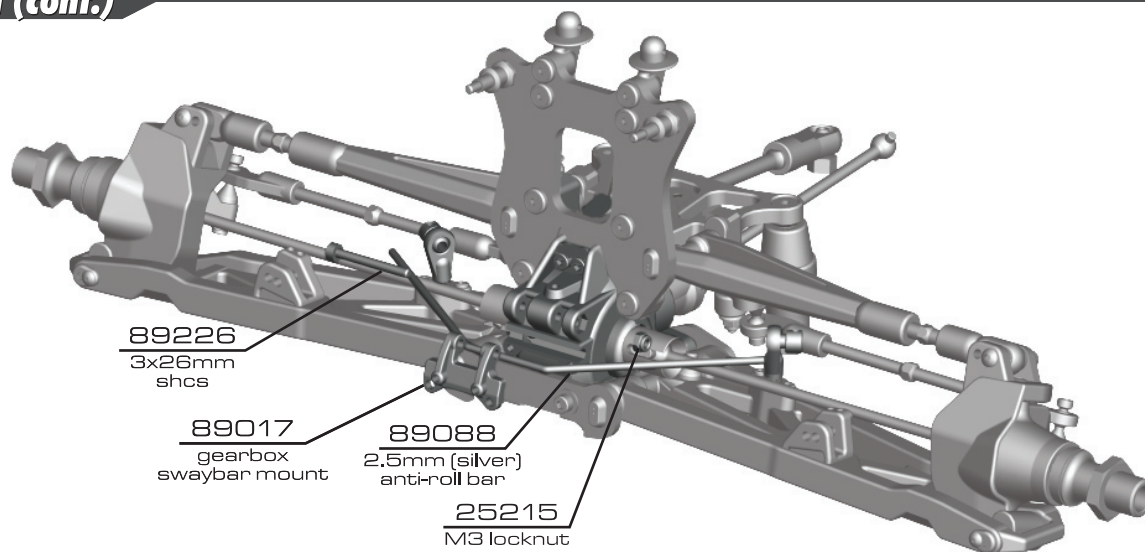

:: Suspension (cont.)

Bag F6

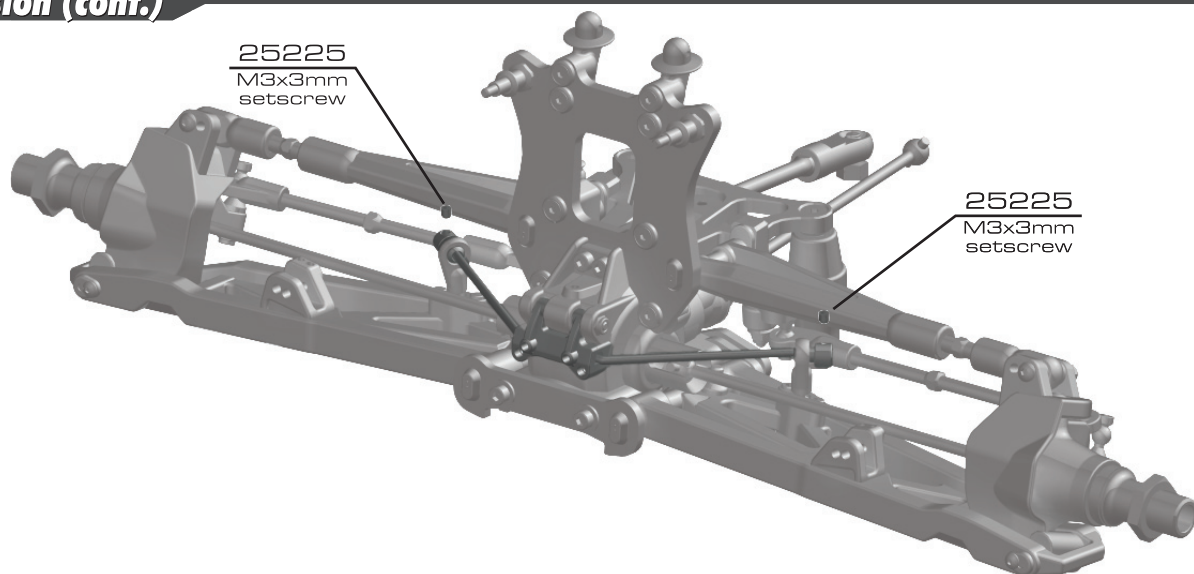

:: Suspension (cont.)

Bag F6

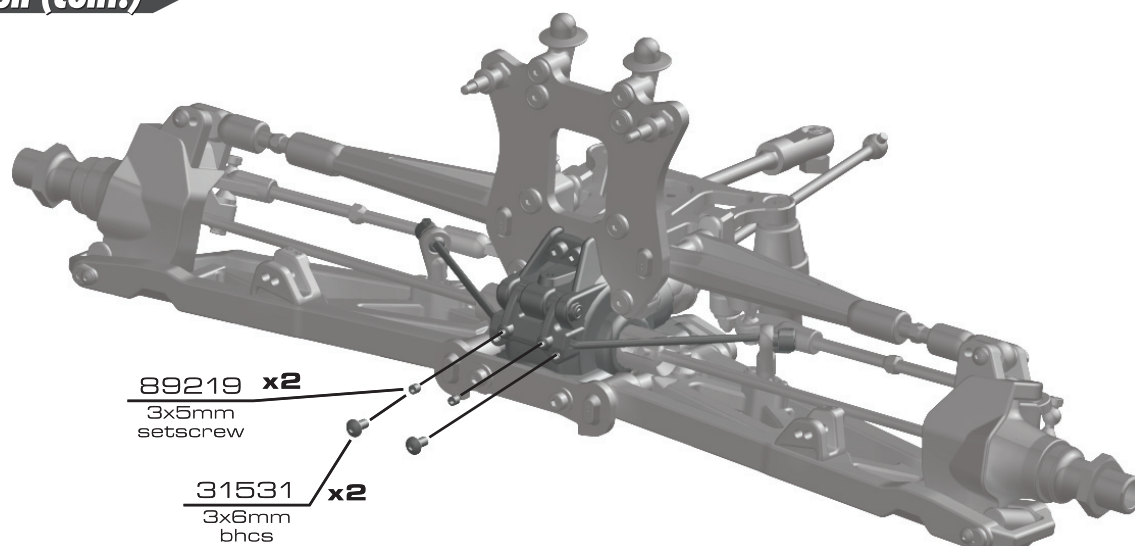

:: Suspension (cont.)

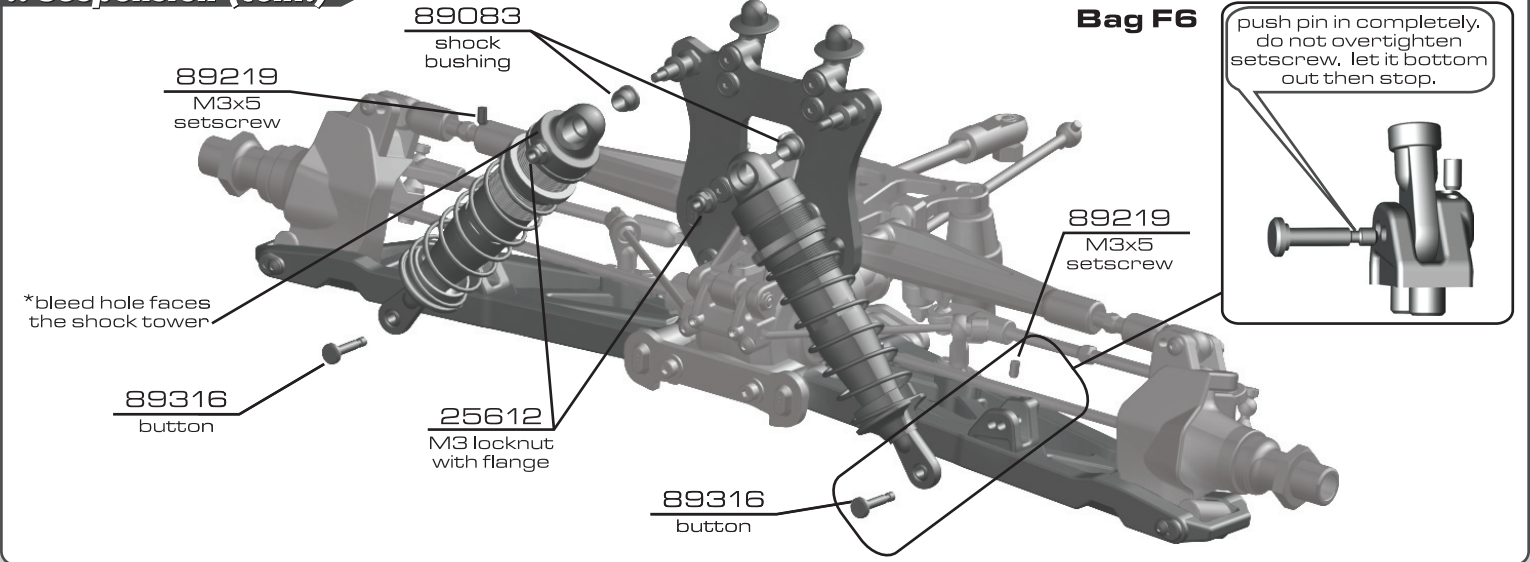

:: Center Diff

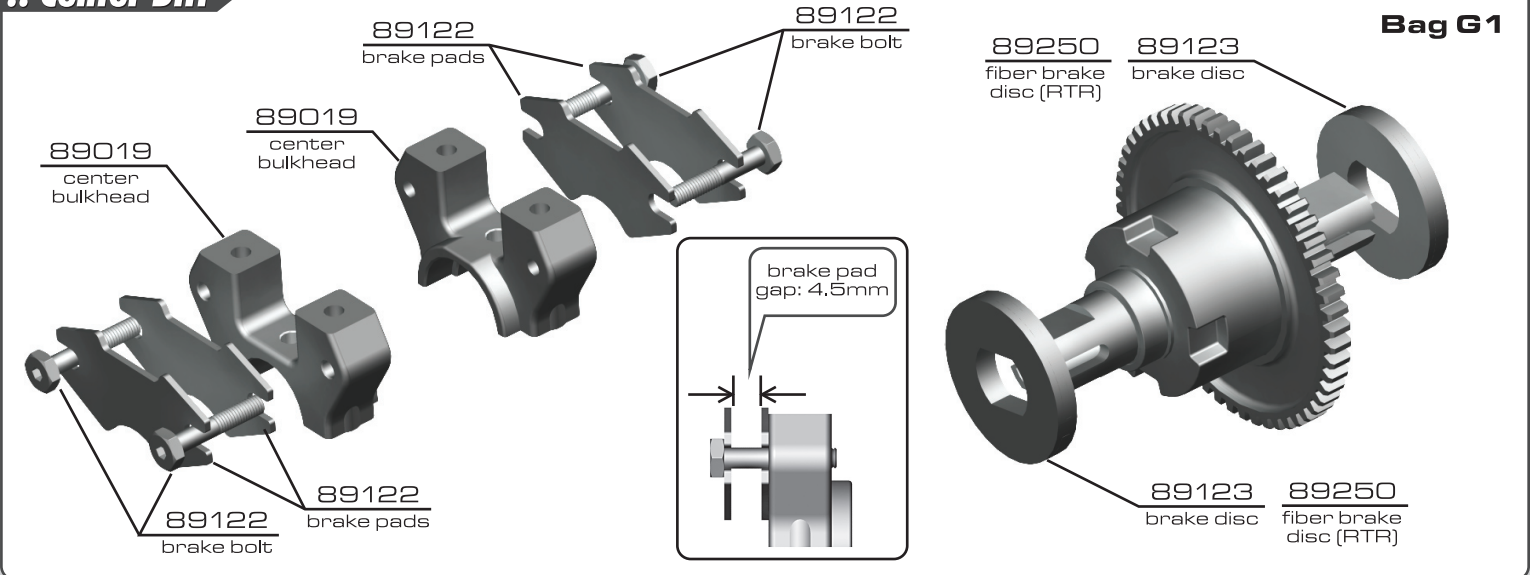

:: Center Diff

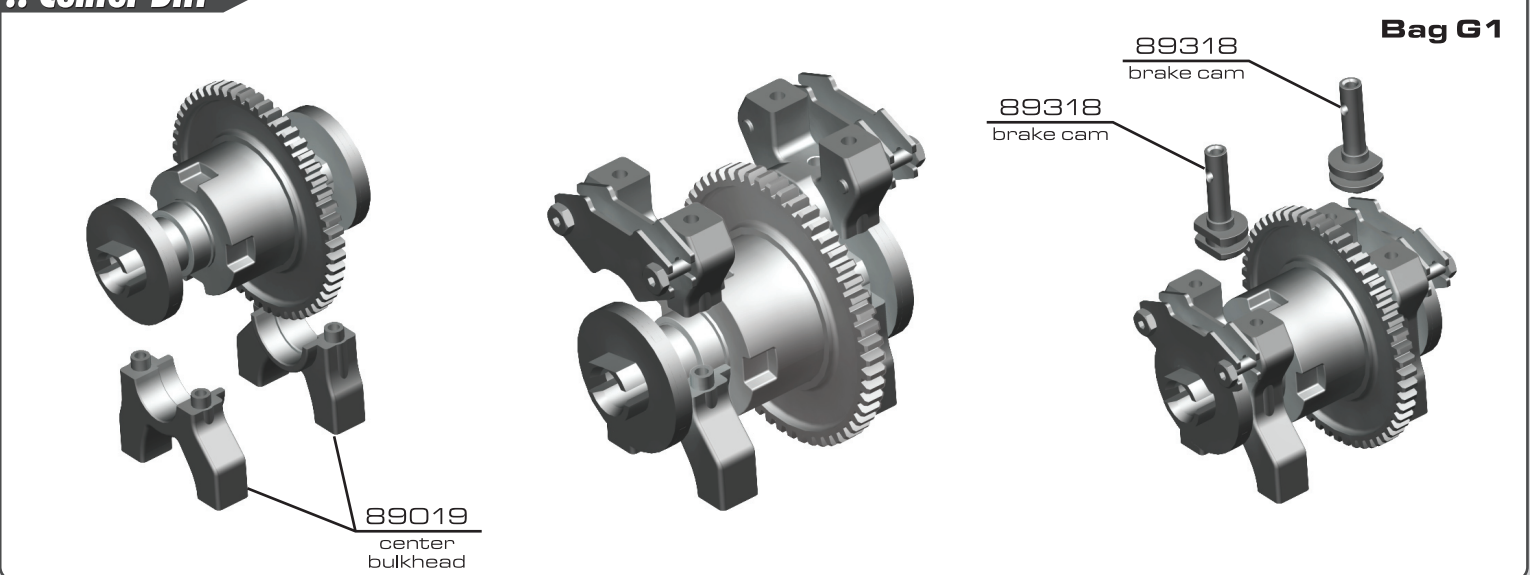

:: Center Diff (cont.)

89205
3x26mm
bhcs x4

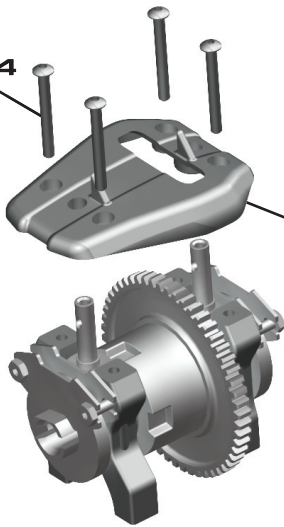

89323
center diff
top plate

89219
M3x5
set screw x2

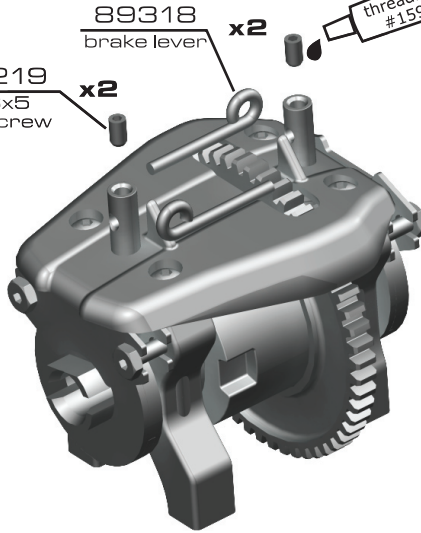

89318
brake lever x2

threadlock
#1596

Bag G1

* after installation,
leave a 0.5mm gap
between the two
brake levers

0.5mm

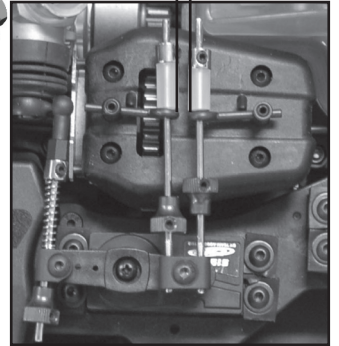

:: Rear Gearbox

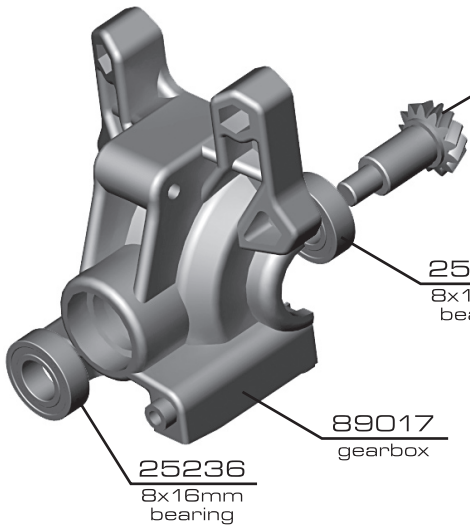

89114
diff pinion
gear

25236
8x16mm
bearing

89017
gearbox

25236
8x16mm
bearing

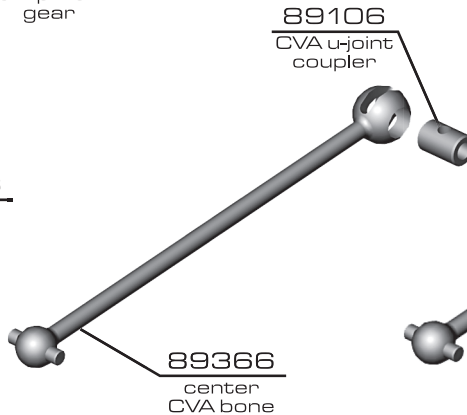

89106
CVA u-joint
coupler

89366
center
CVA bone

89106
CVA pin **Bag H1/H2**

89104
CVA input
cup



:: Rear Gearbox

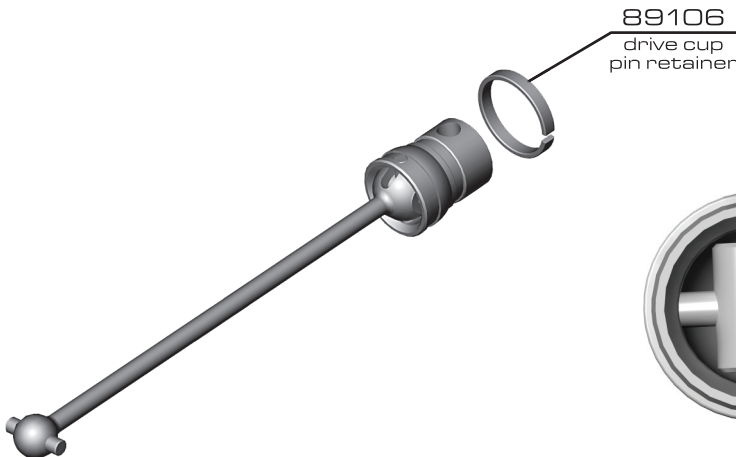

89106
drive cup
pin retainer

note:
align gap
opposite
of CVA pin



89221
5x4mm
setscrew

threadlock
#1596

Bag H2

no end
play

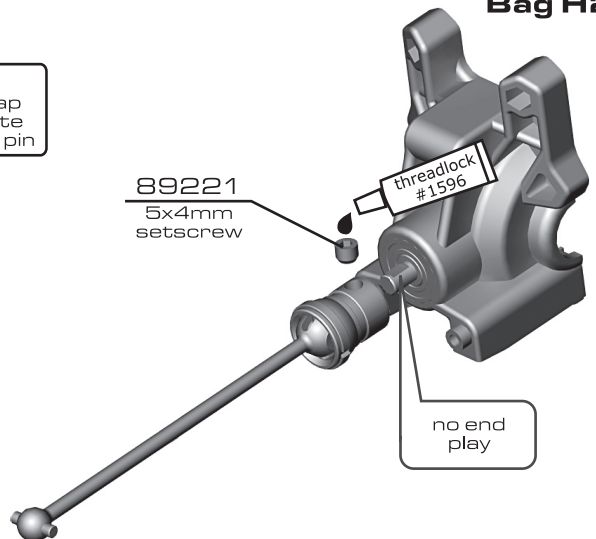

:: Rear Gearbox (cont.)

Bag H3

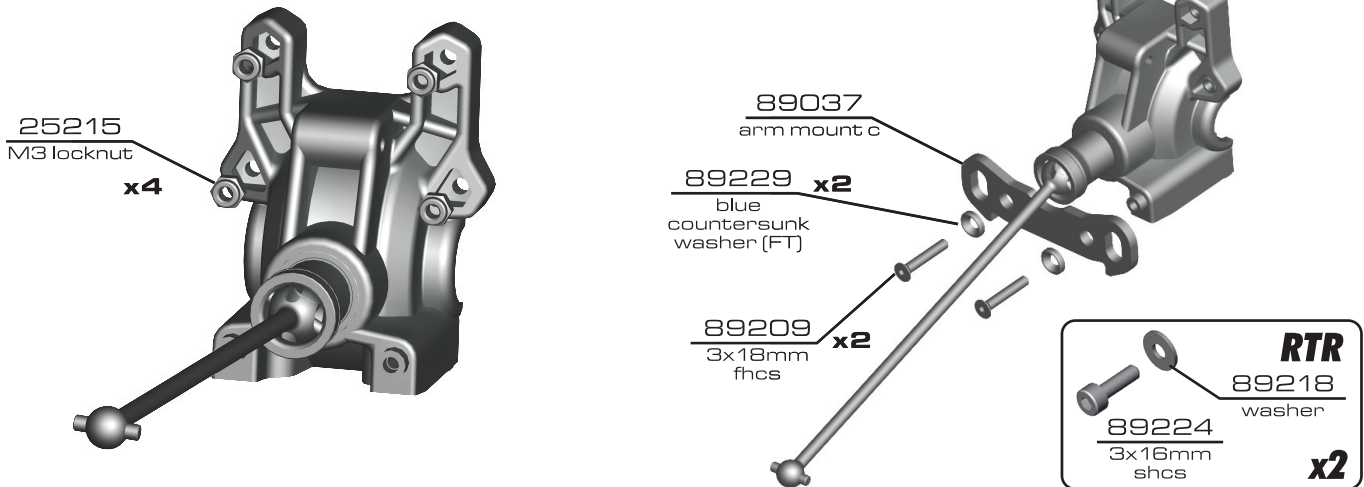

:: Rear Gearbox (cont.)

Bag H3

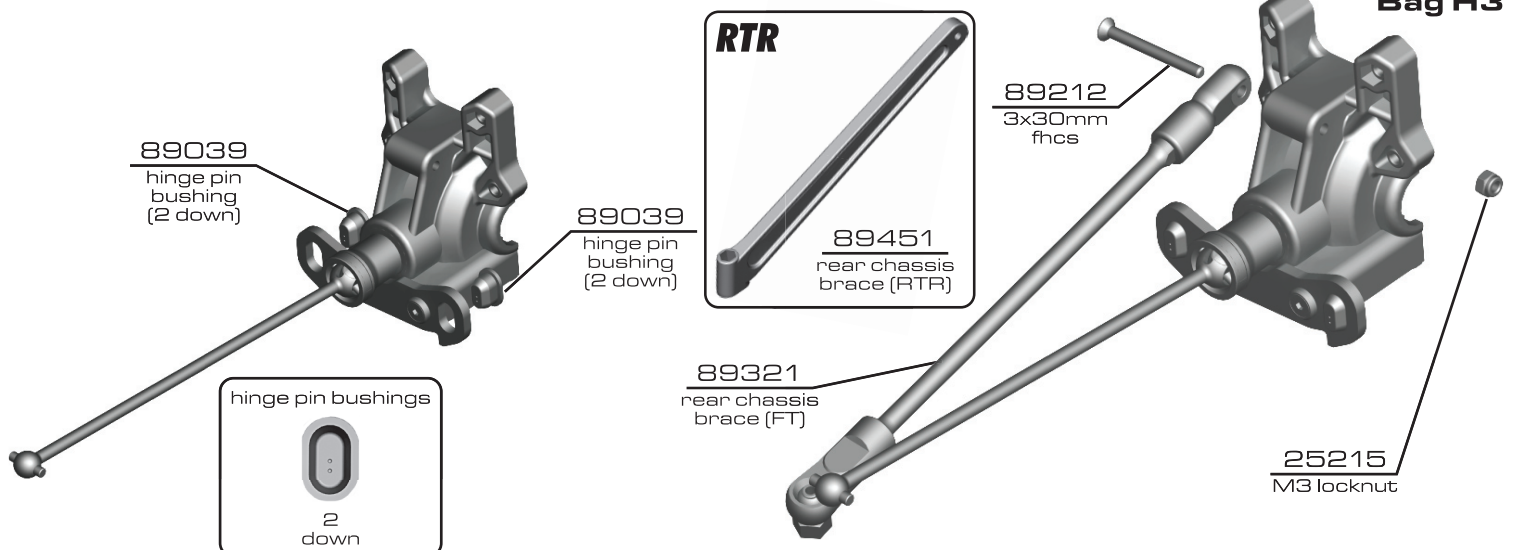

:: Rear Gearbox (cont.)

Bag H4

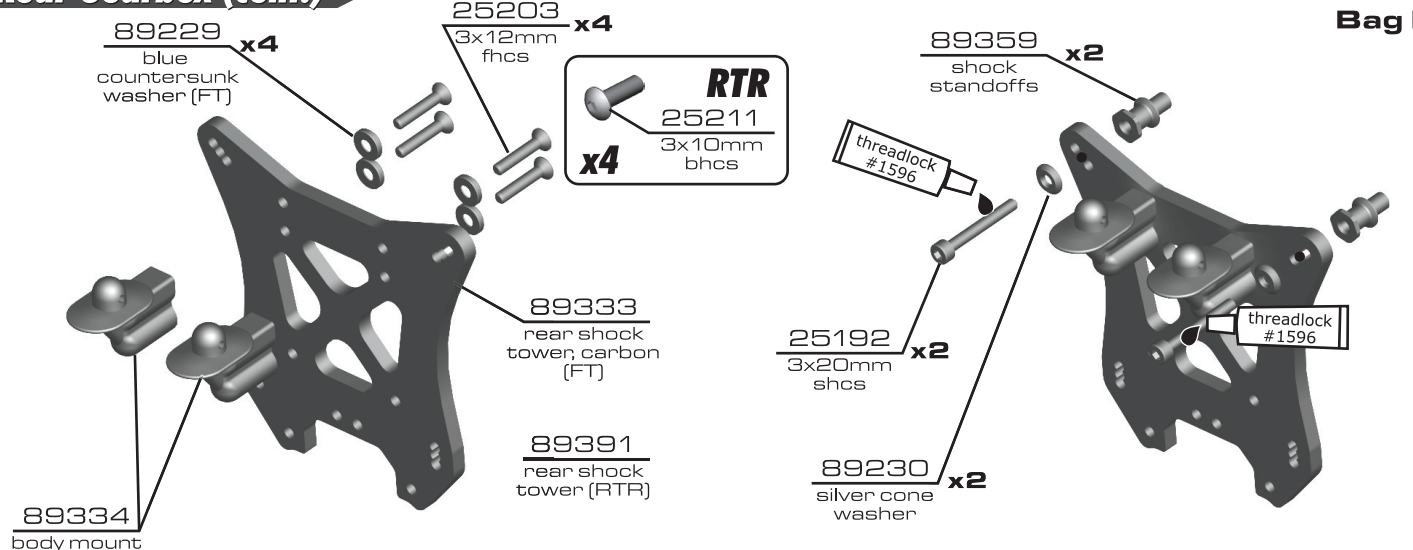

:: Rear Gearbox (cont.)

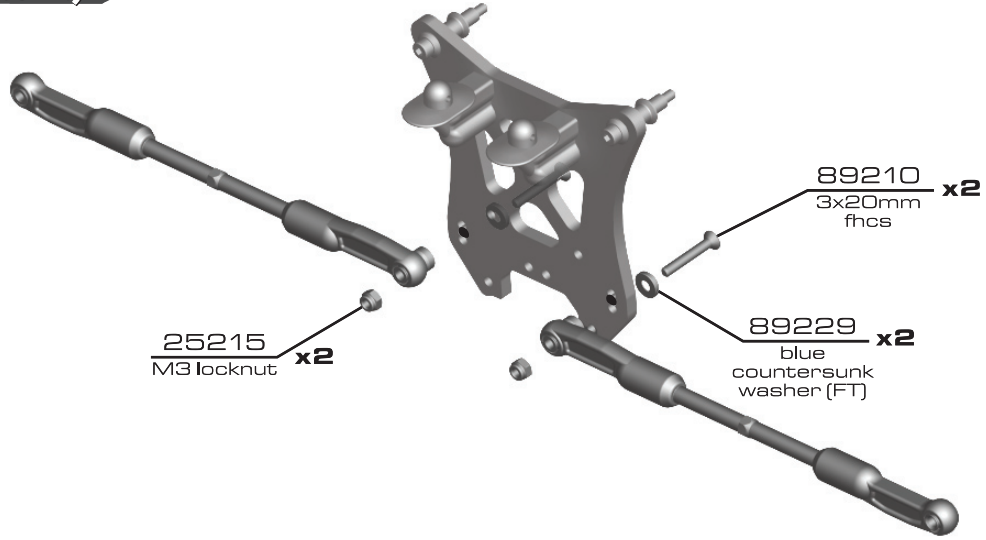

Bag H4

RTR
x2
25188
3x20mm
bhcs

:: Rear Gearbox (cont.)

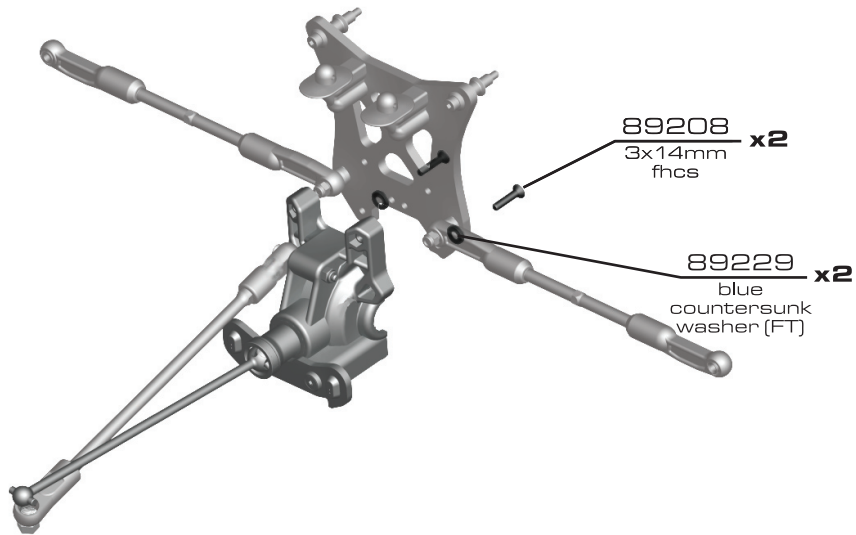

Bag H4

RTR
x2
89202
3x12mm
bhcs

:: Rear Gearbox (cont.)

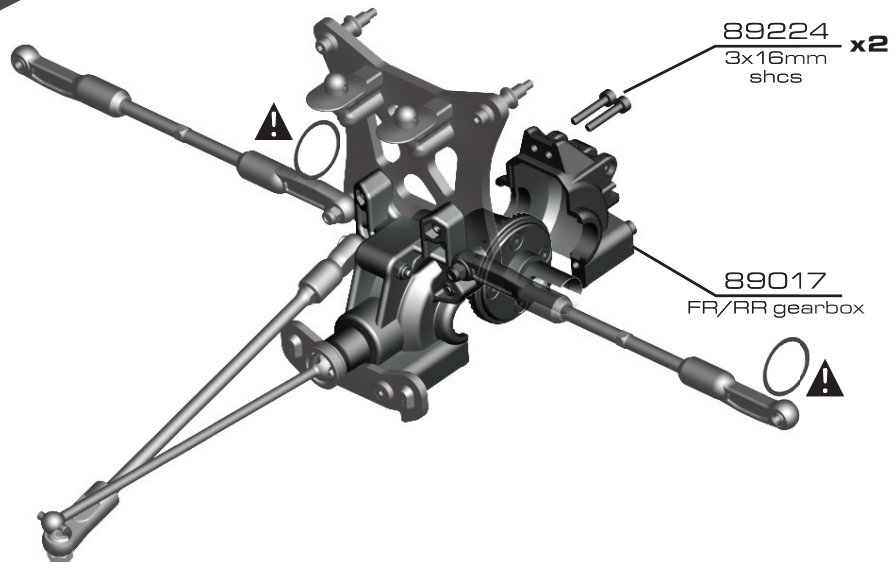

Bag H4



*remember to install the diff shims between the diff casing and bearings before inserting diff into the gearbox



:: Suspension

Bag I1

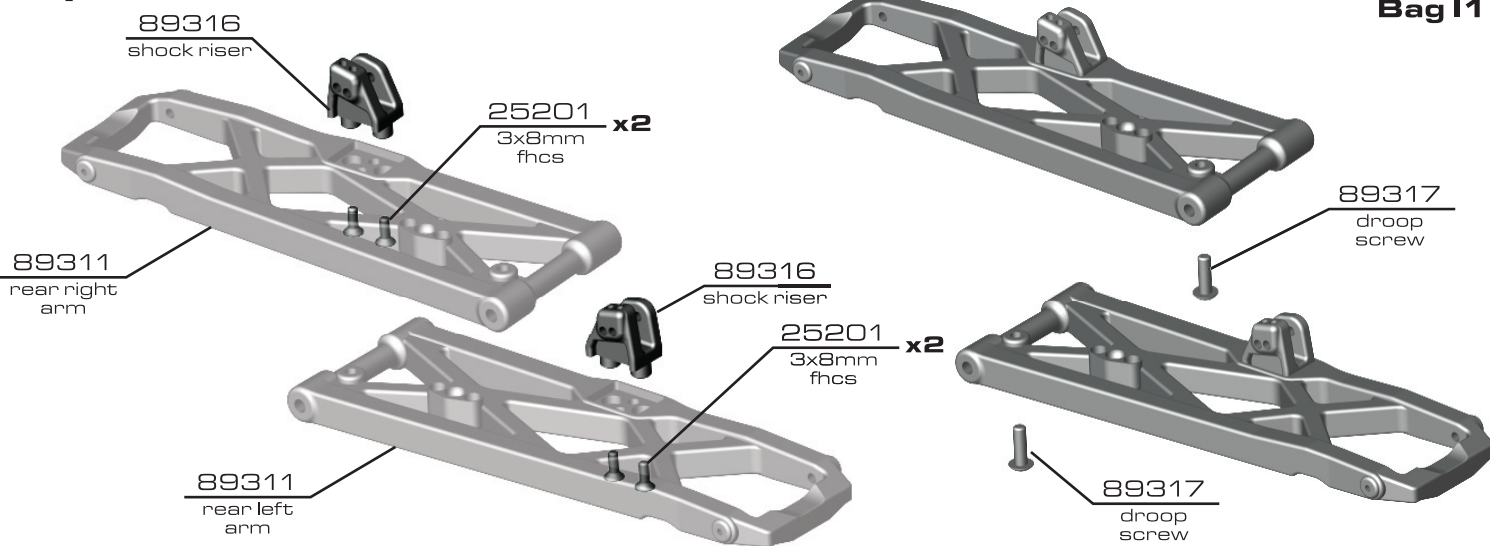

:: Suspension (cont.)

Bag I1

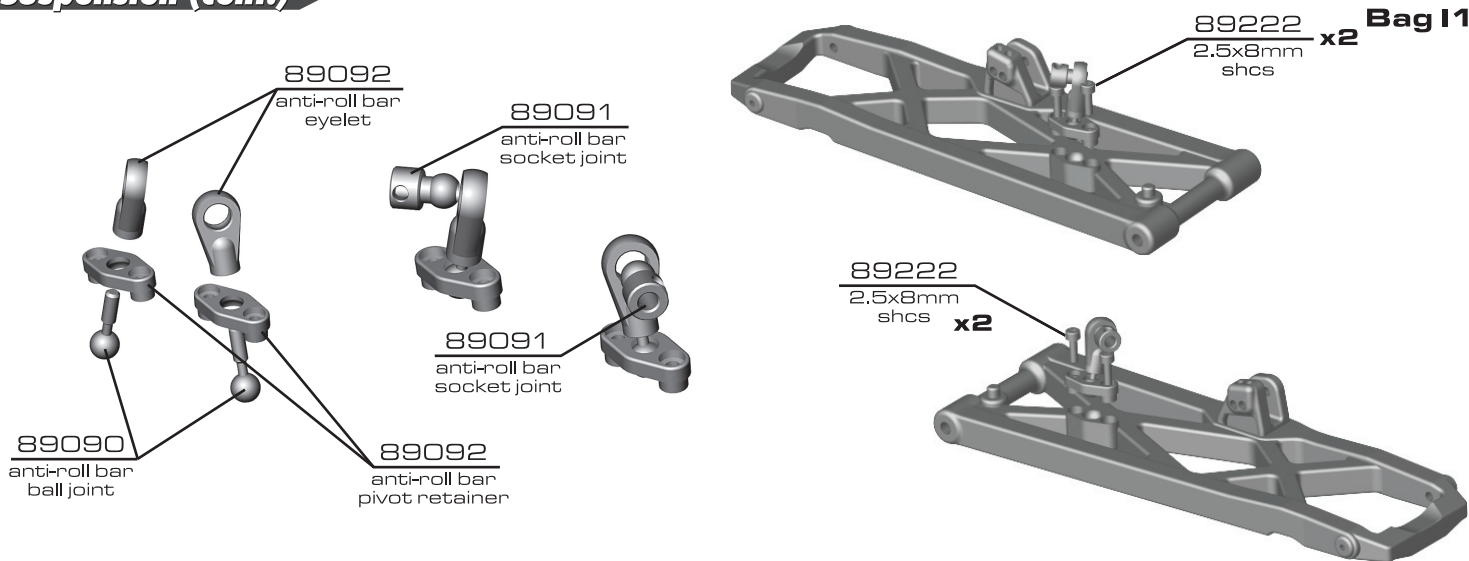

:: Suspension (cont.)

Bag I2/I3

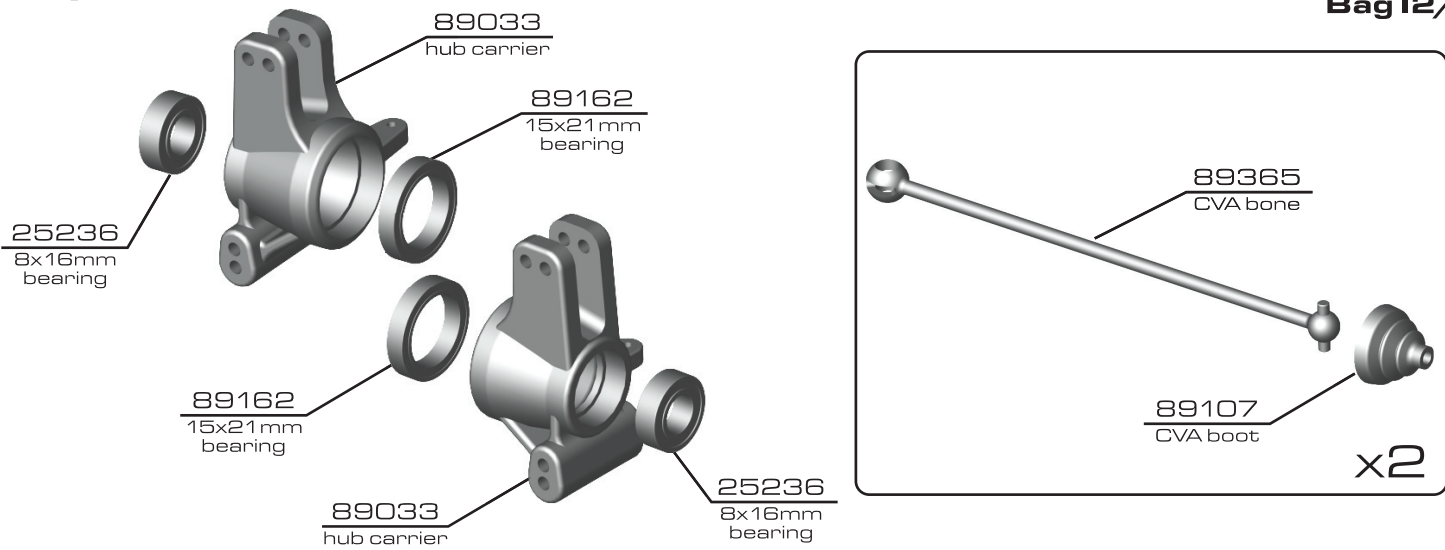

:: Suspension (cont.)

Bag I3

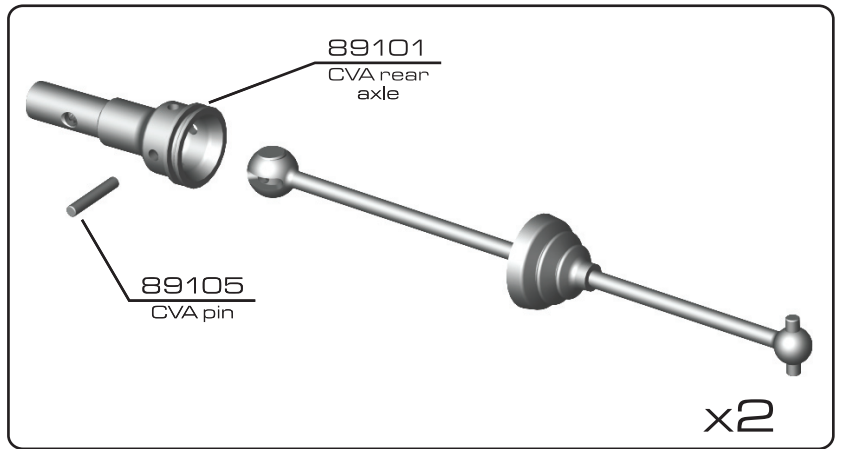
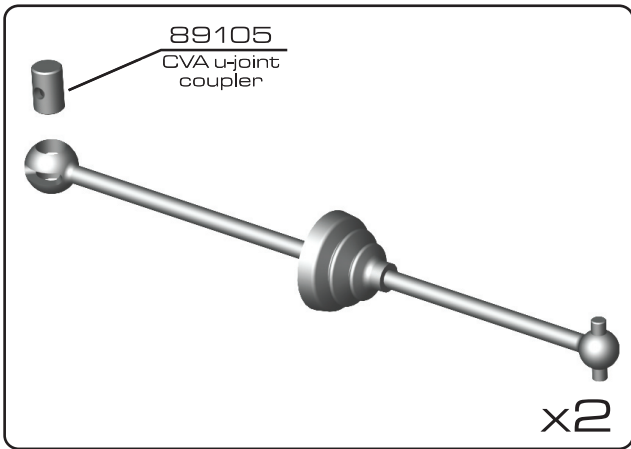

:: Suspension (cont.)

Bag I3

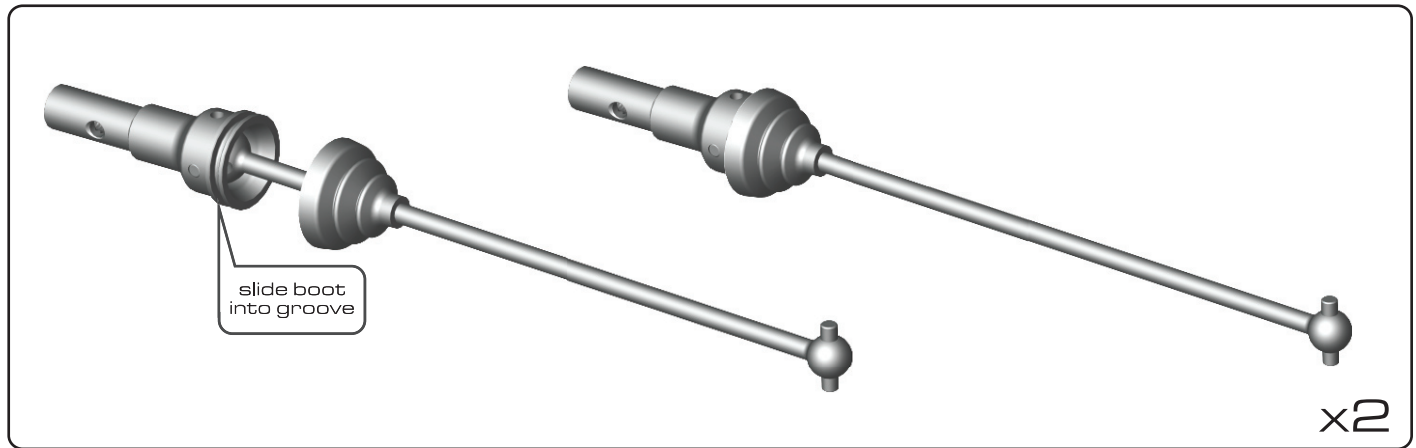

:: Suspension (cont.)

Bag I3

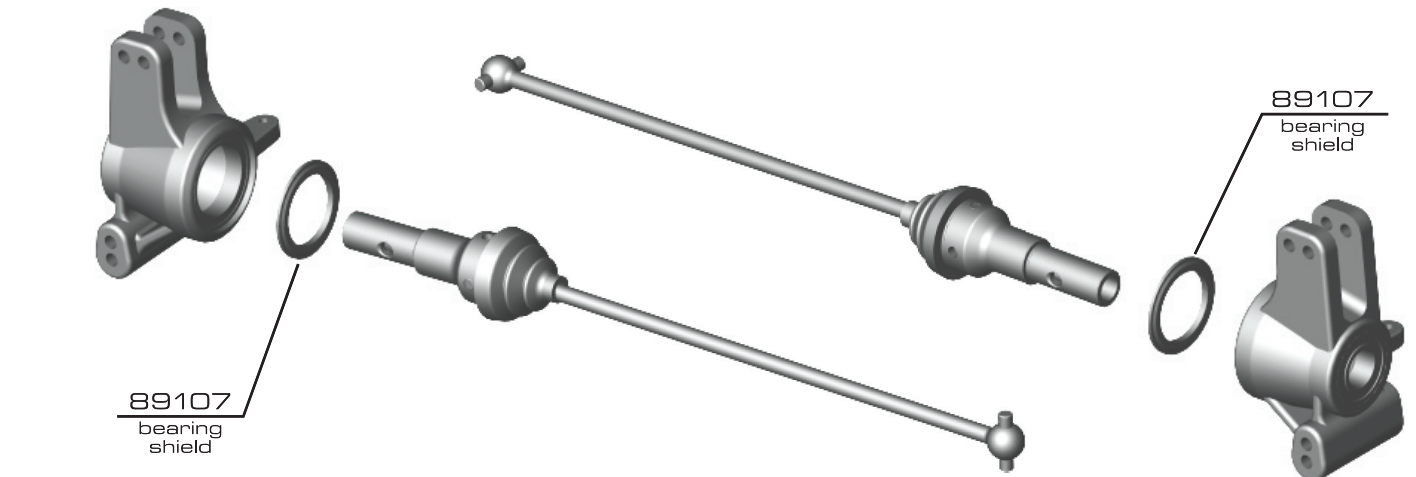

:: Suspension (cont.)

Bag I3



:: Suspension (cont.)

Bag I4

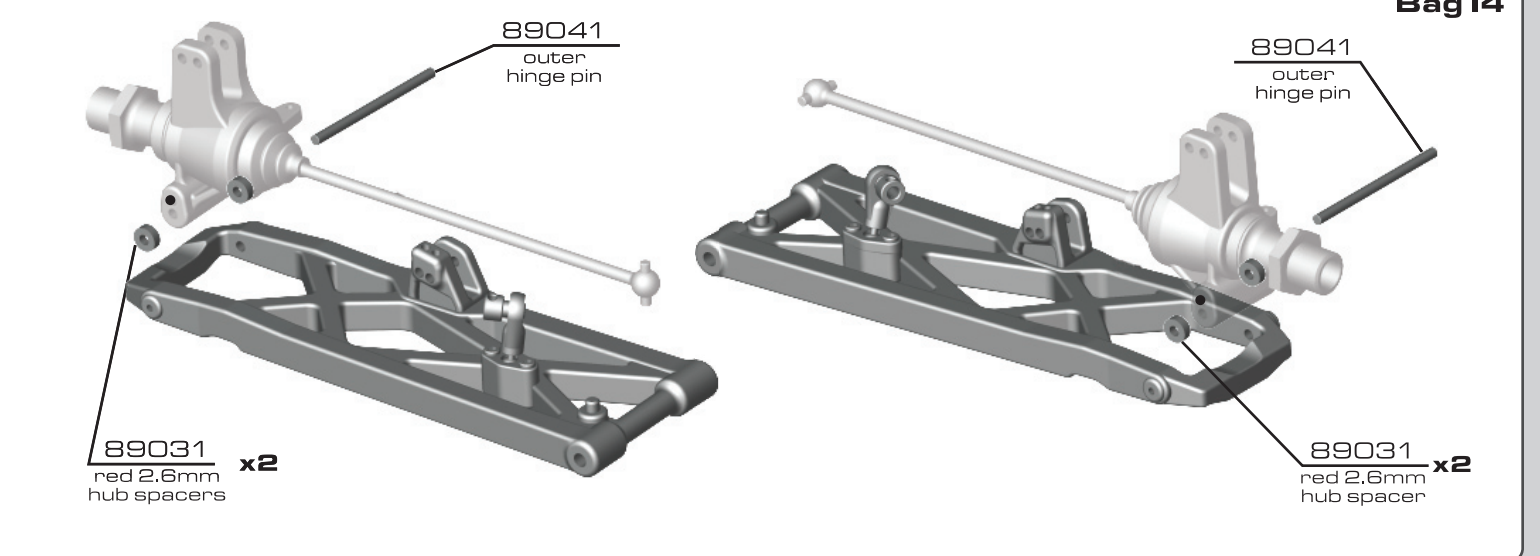

:: Suspension (cont.)

Bag I4

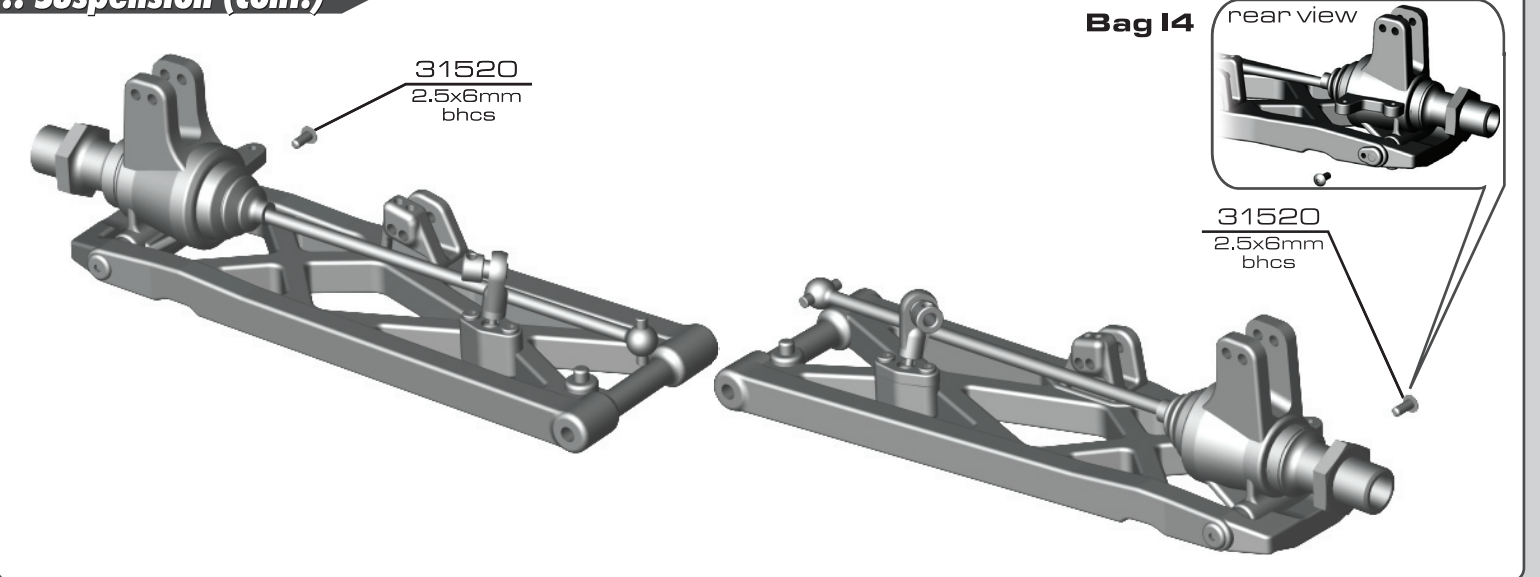

:: Suspension (cont.)

Bag I4

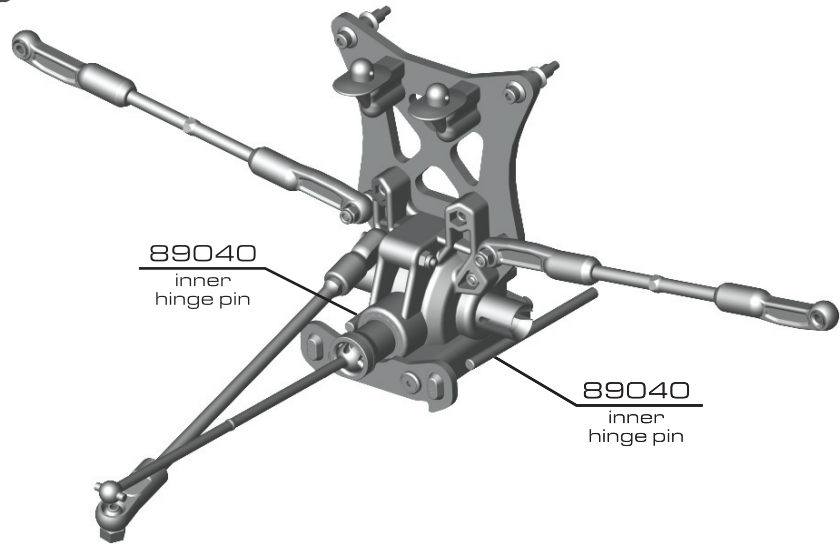

:: Suspension (cont.)

Bag I4

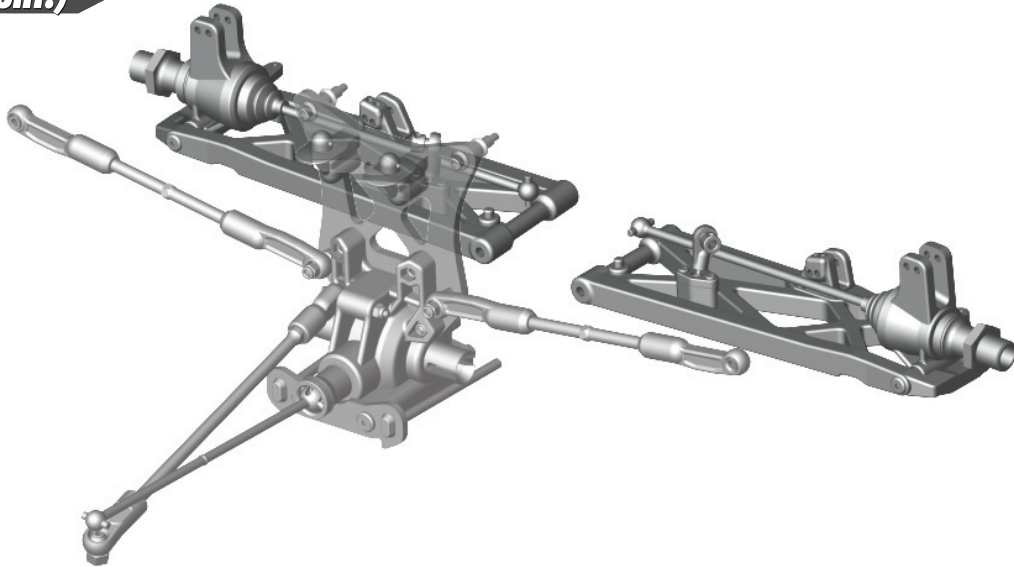

:: Suspension (cont.)

Bag I4

89278
2.5mm
washer

threadlock
#1596

89201
2.5x3mm
bhcs

threadlock
#1596

89278
2.5mm
washer

89038
arm mount d
(3 degree)

89279
3x45mm
shcs x2

89230
silver cone
washer x2

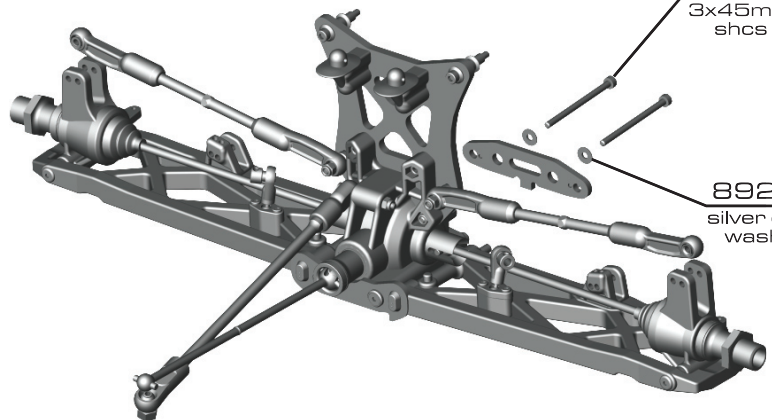

:: Suspension (cont.)

Bag I4

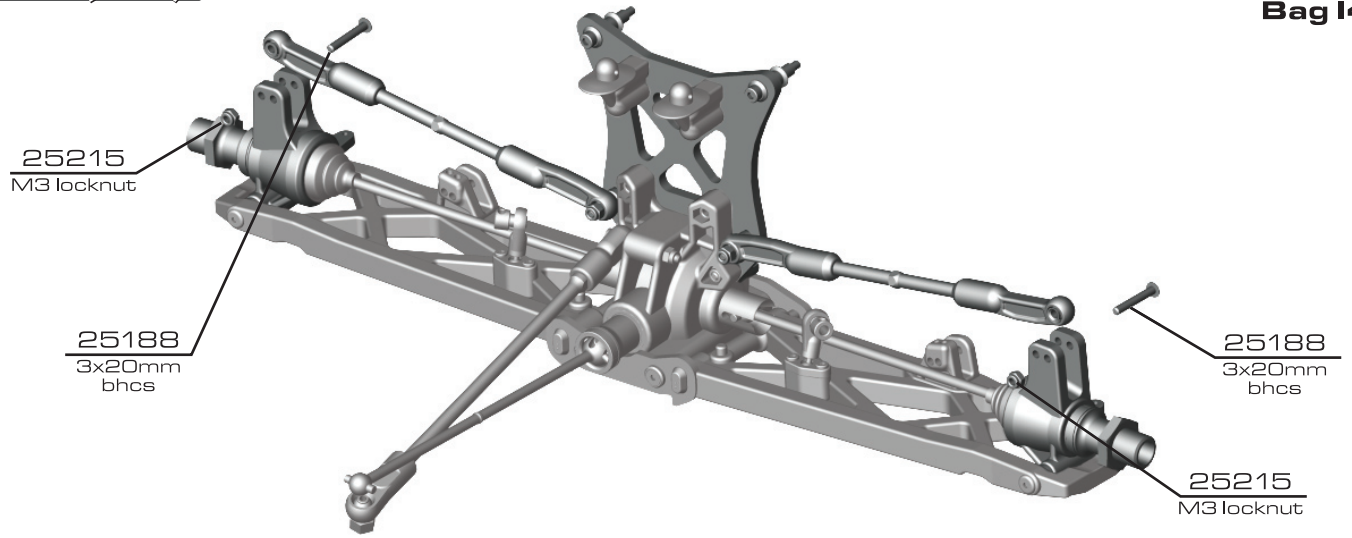

:: Suspension (cont.)

Bag I5

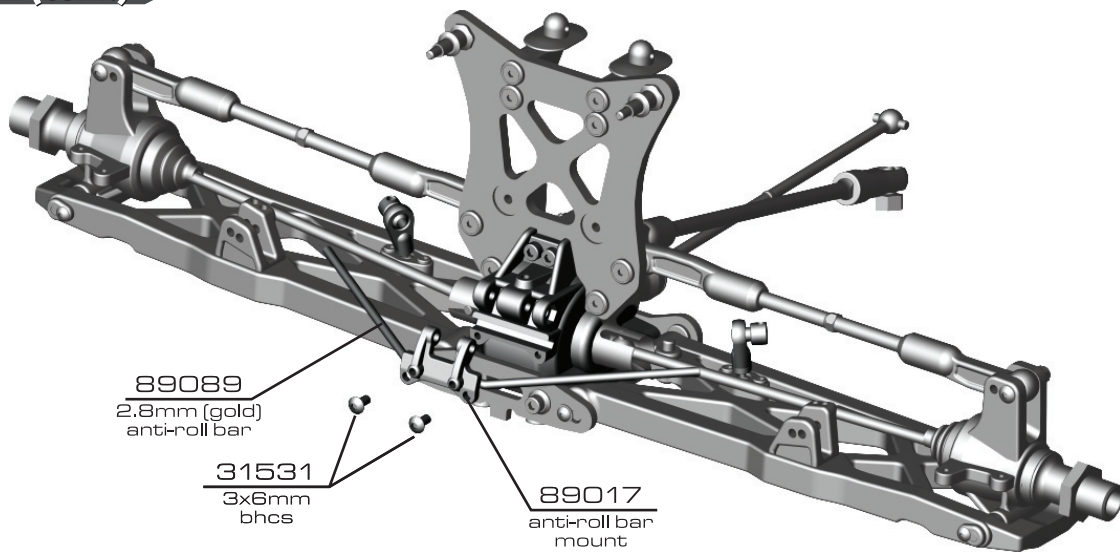

:: Suspension (cont.)

Bag I5

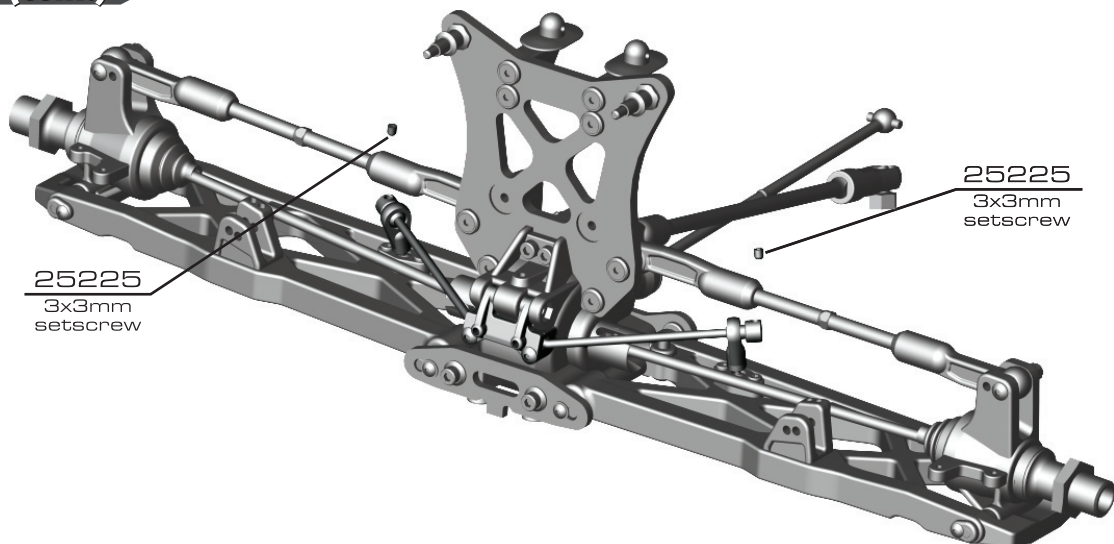

:: Suspension (cont.)

Bag I5

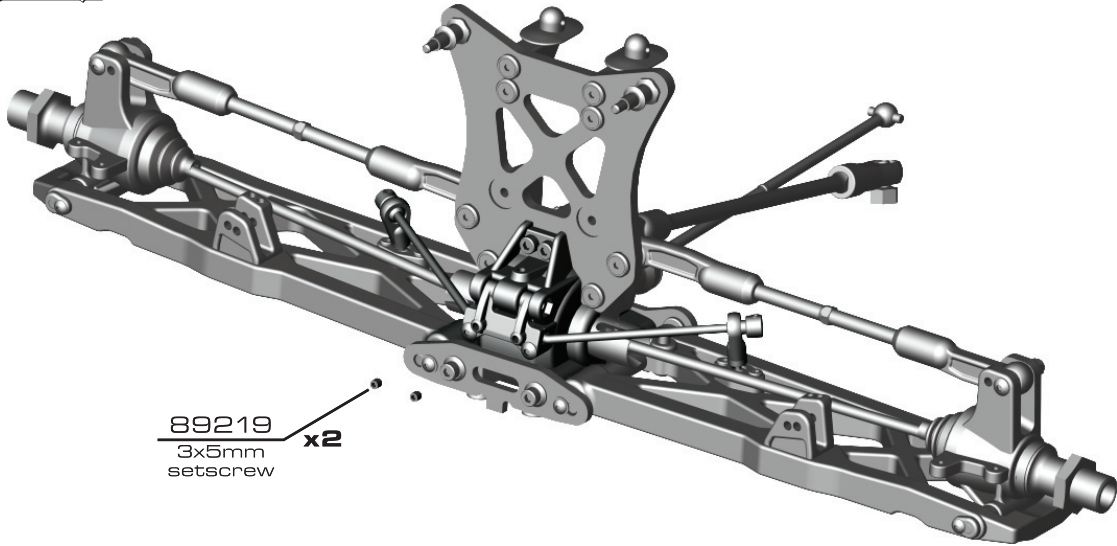

89219
3x5mm
setscrew x2

:: Suspension (cont.)

Bag I5

push pin in completely, do not over tighten setscrew, let it bottom out then stop.

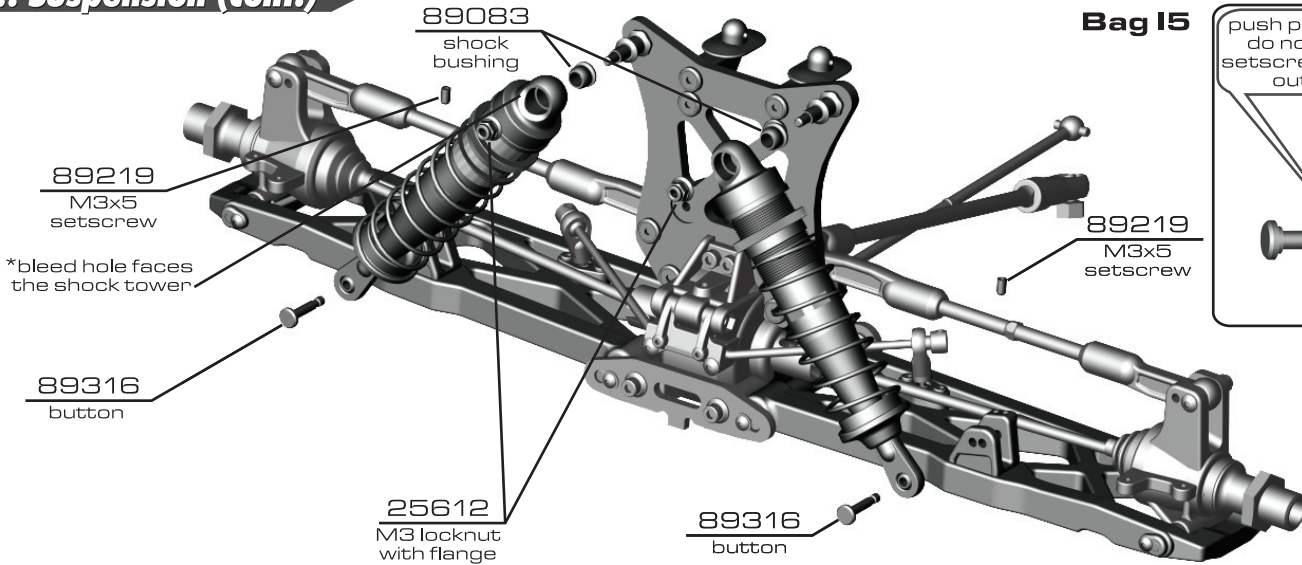
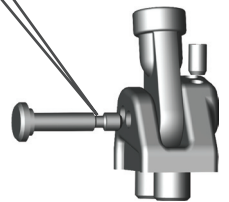

89083
shock
bushing

89219
M3x5
setscrew

*bleed hole faces
the shock tower

89219
M3x5
setscrew

89316
button

25612
M3 locknut
with flange

89316
button

:: Wing

Bag J1

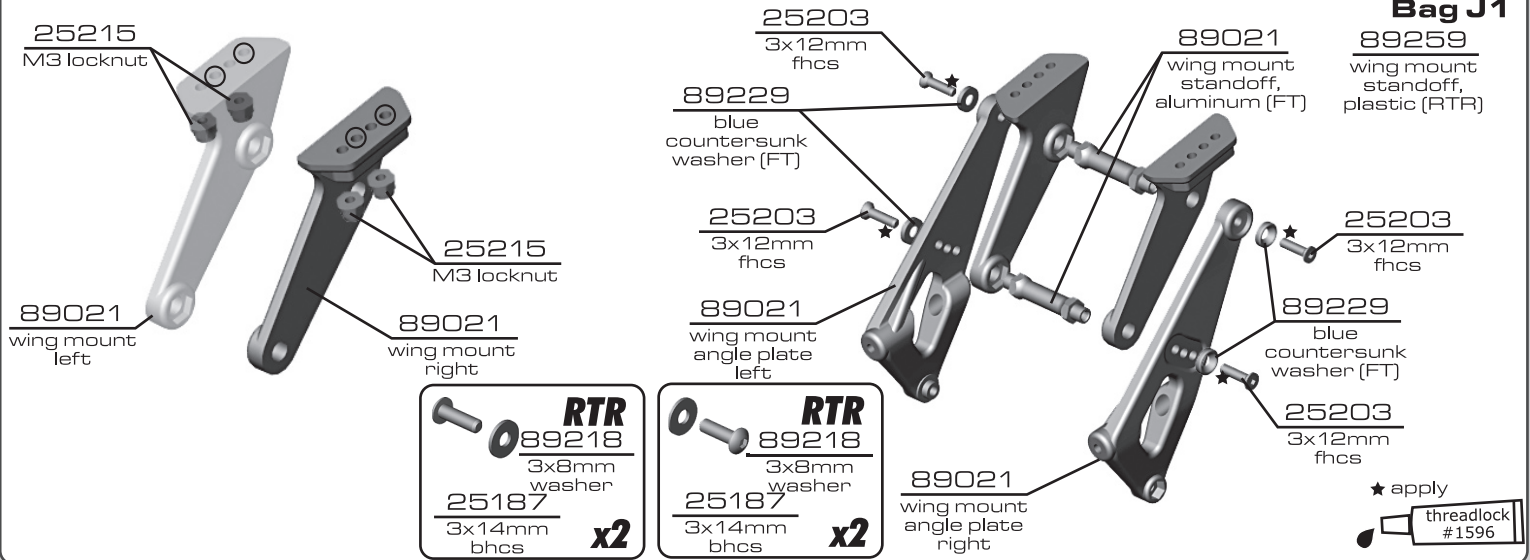

25215
M3 locknut

25203
3x12mm
fhcs

89021
wing mount
standoff,
aluminum (FT)

89259
wing mount
standoff,
plastic (RTR)

89229
blue
countersunk
washer (FT)

25203
3x12mm
fhcs

89021
wing mount
angle plate
left

25203
3x12mm
fhcs

89229
blue
countersunk
washer (FT)

25203
3x12mm
fhcs

89021
wing mount
left

25215
M3 locknut

89021
wing mount
right

RTR
89218
3x8mm
washer
25187
3x14mm
bhcs x2

RTR
89218
3x8mm
washer
25187
3x14mm
bhcs x2

89021
wing mount
angle plate
right

★ apply
threadlock
#1596

:: Wing (cont.)

- RTR**
- 89218**
- 3x8mm washer
- 25211**
- 3x10mm bhcs
- x4**

- 25203**
- 3x12mm fhcs
- x4**

- 89229**
- blue countersunk washer (FT)
- x4**

- 89156**
- wing

*fit onto transmission case

Bag J2

- 25192**
- 3x20mm shcs
- x2**

:: Wing (cont.)

Bag J2

- 25215**
- M3 locknut

- 89228**
- 3x40mm shcs

:: Chassis Assembly

Bag K1

- 89001**
- side guard right

- 89001**
- side guard left

- 25201**
- 3x8mm fhcs
- x6**

- 89450**
- chassis (RTR)

- 89314**
- chassis (FT)

:: Chassis Assembly (cont.)

Bag K2

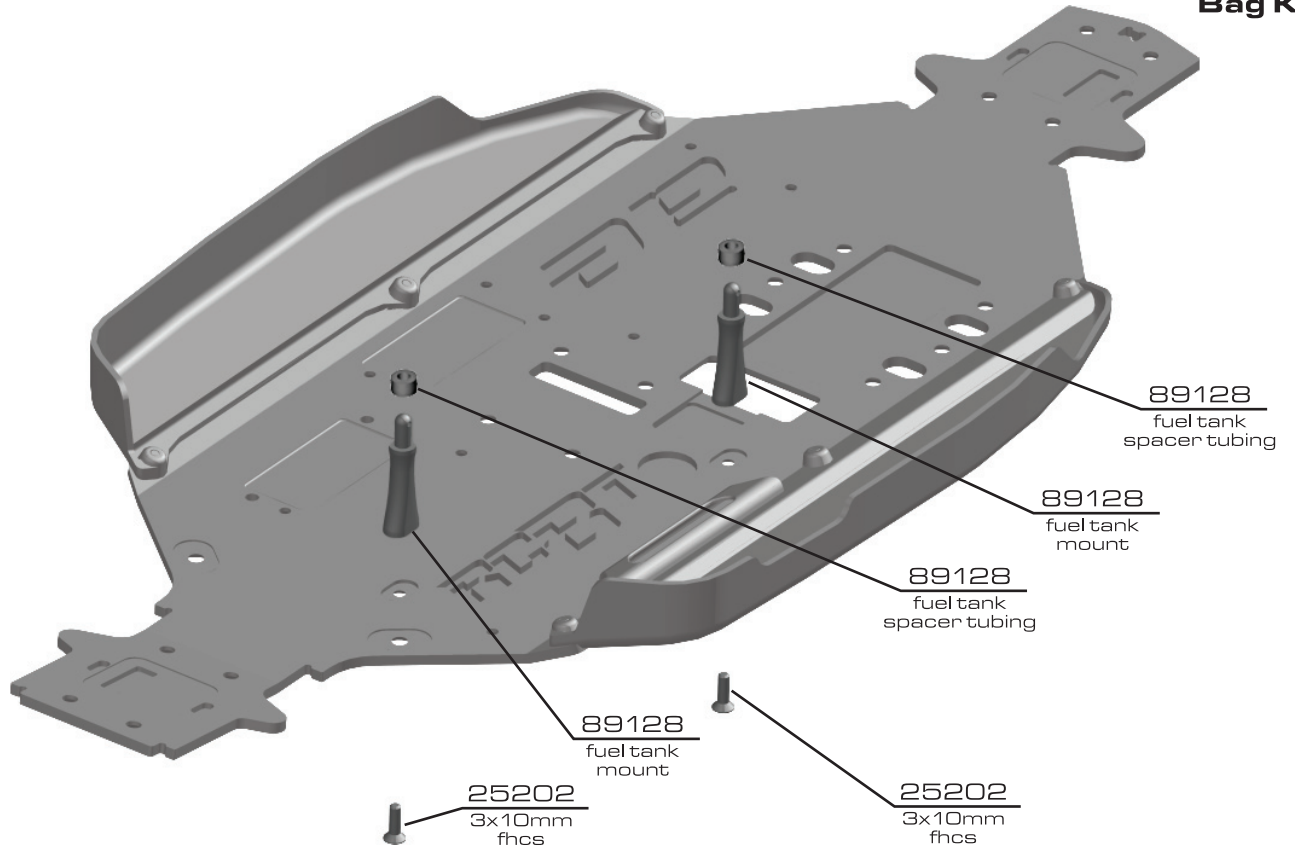

:: Chassis Assembly (cont.)

Bag K3

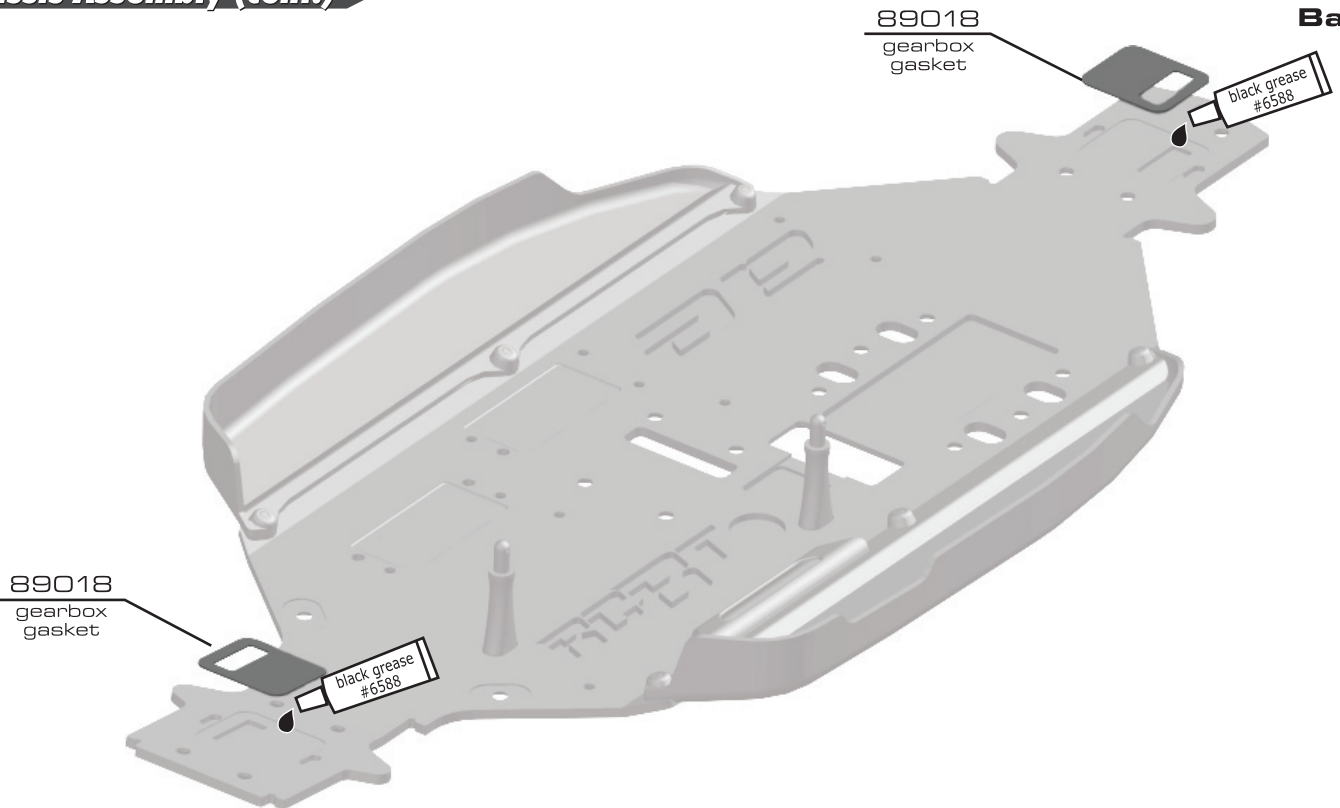

:: Chassis Assembly (cont.)

Bag K3

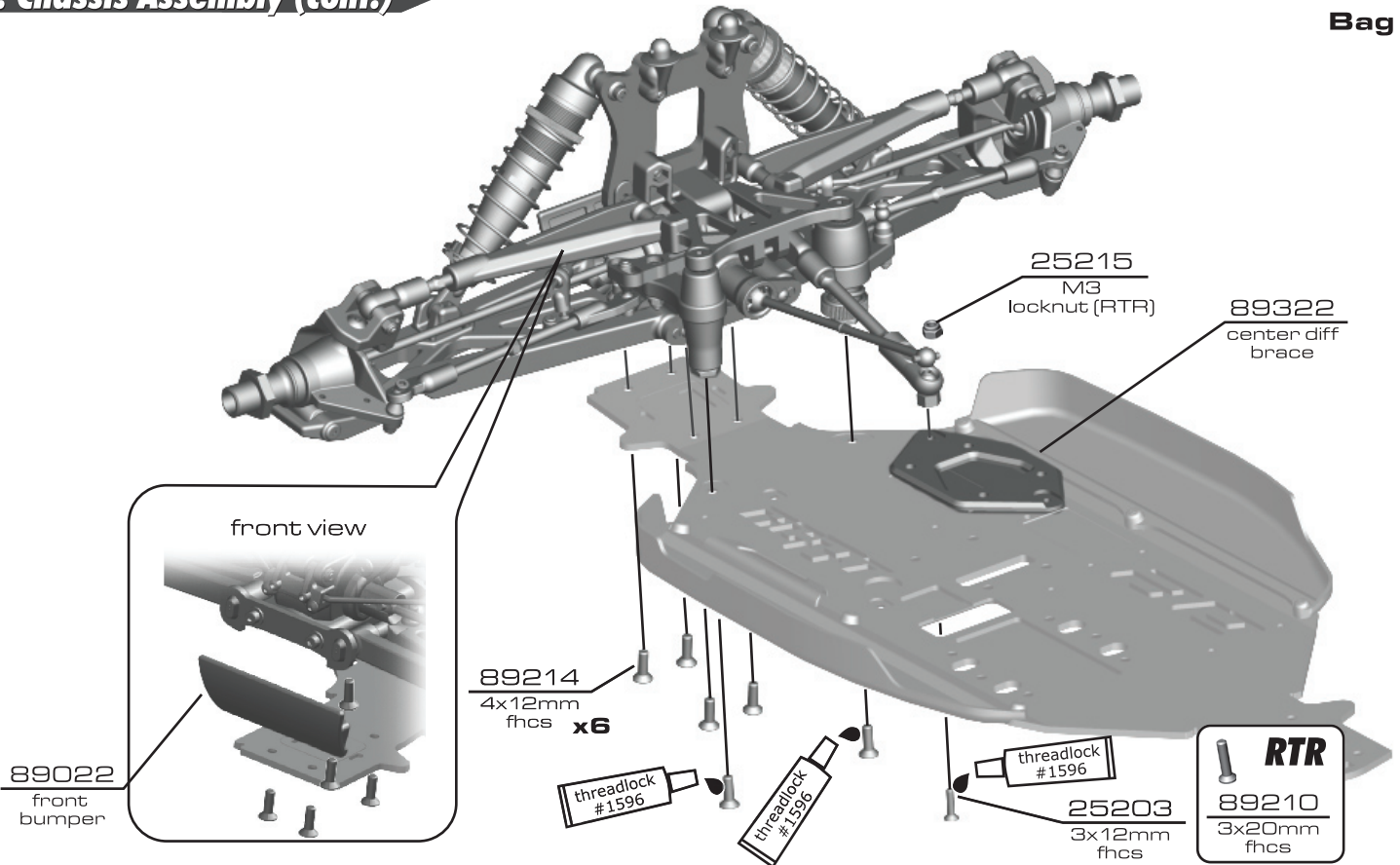

:: Chassis Assembly (cont.)

Bag K3

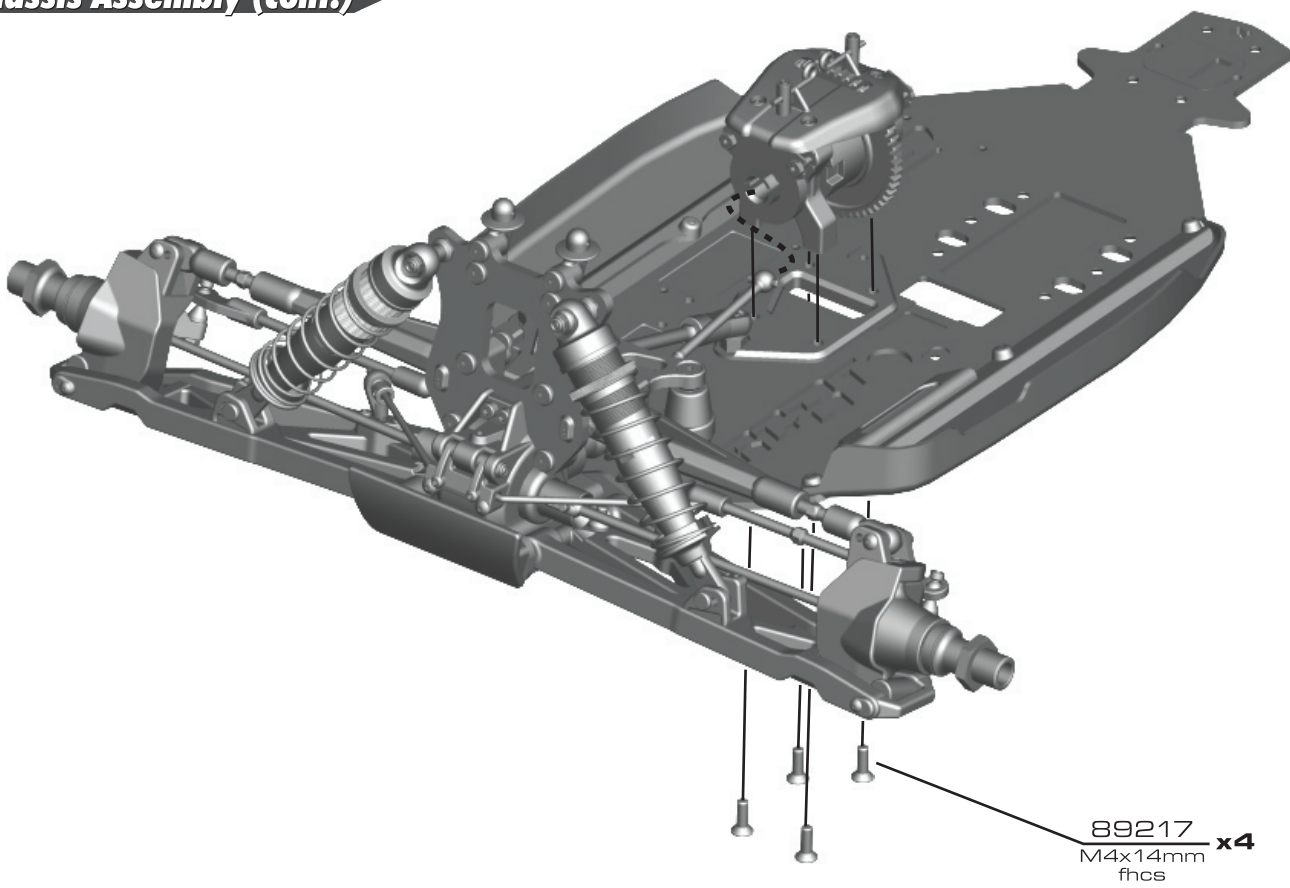

:: Chassis Assembly (cont.)

Bag K3

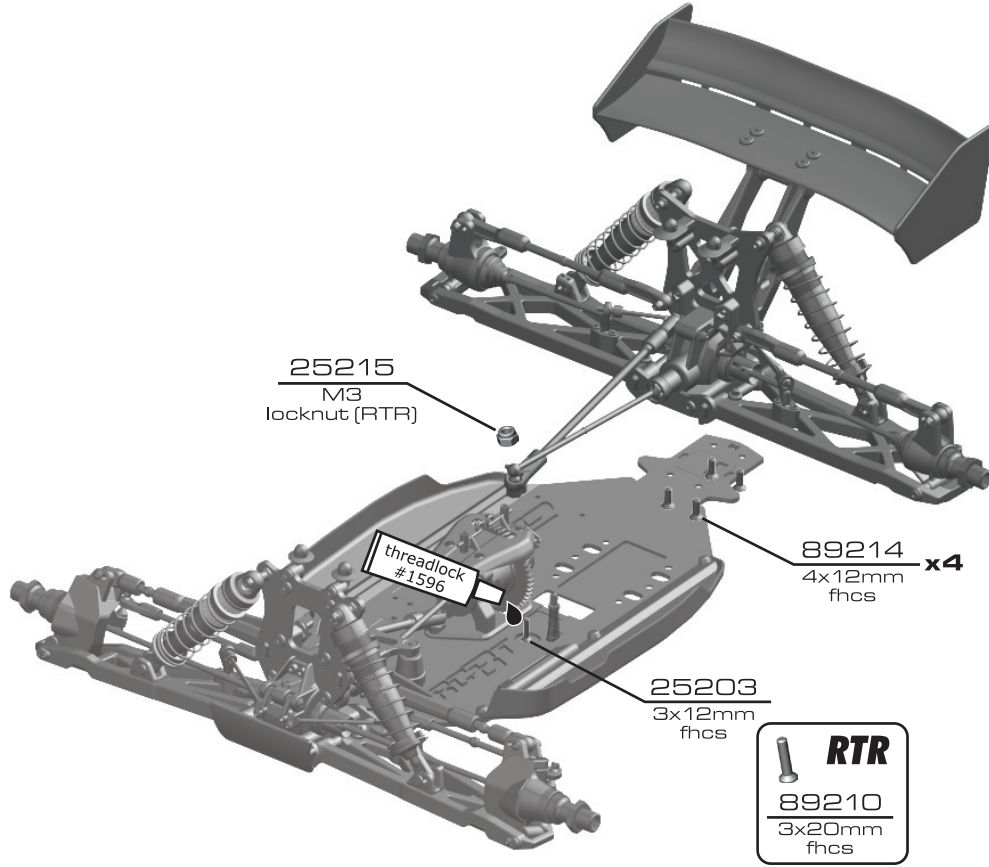

:: Chassis Assembly (cont.)

Bag K4

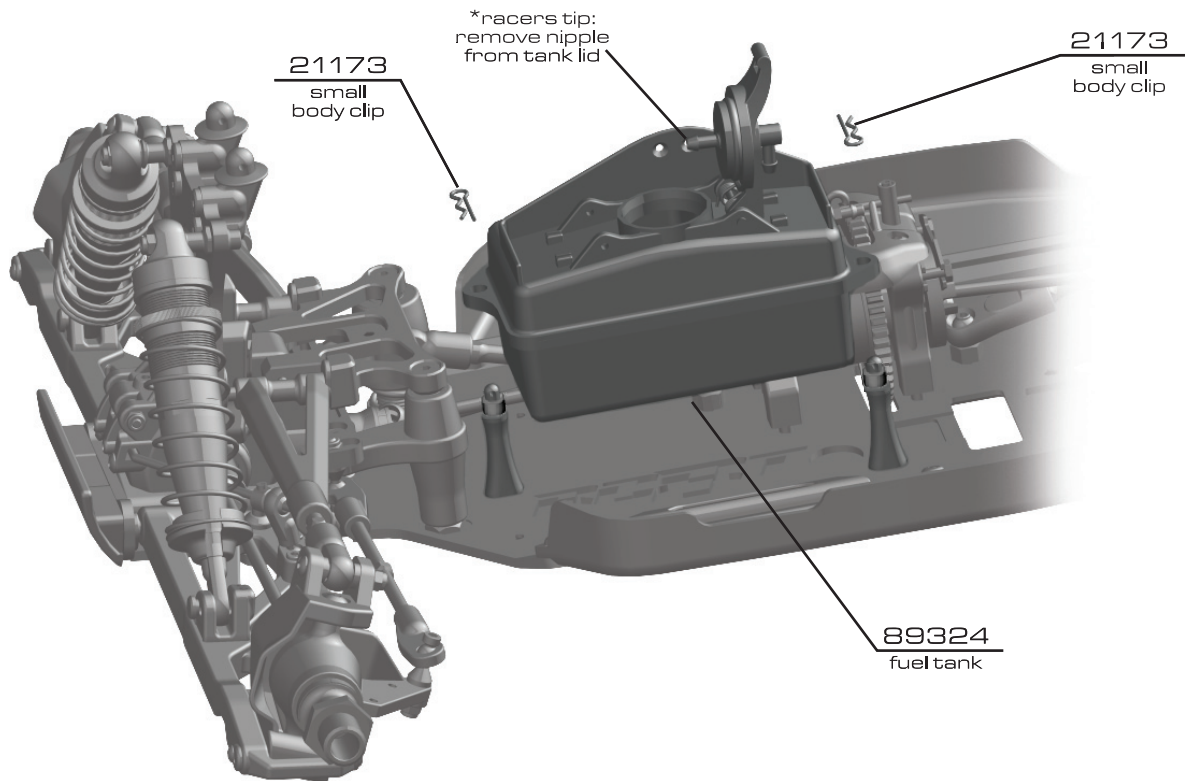

:: Chassis Assembly (cont.)

Bag K5

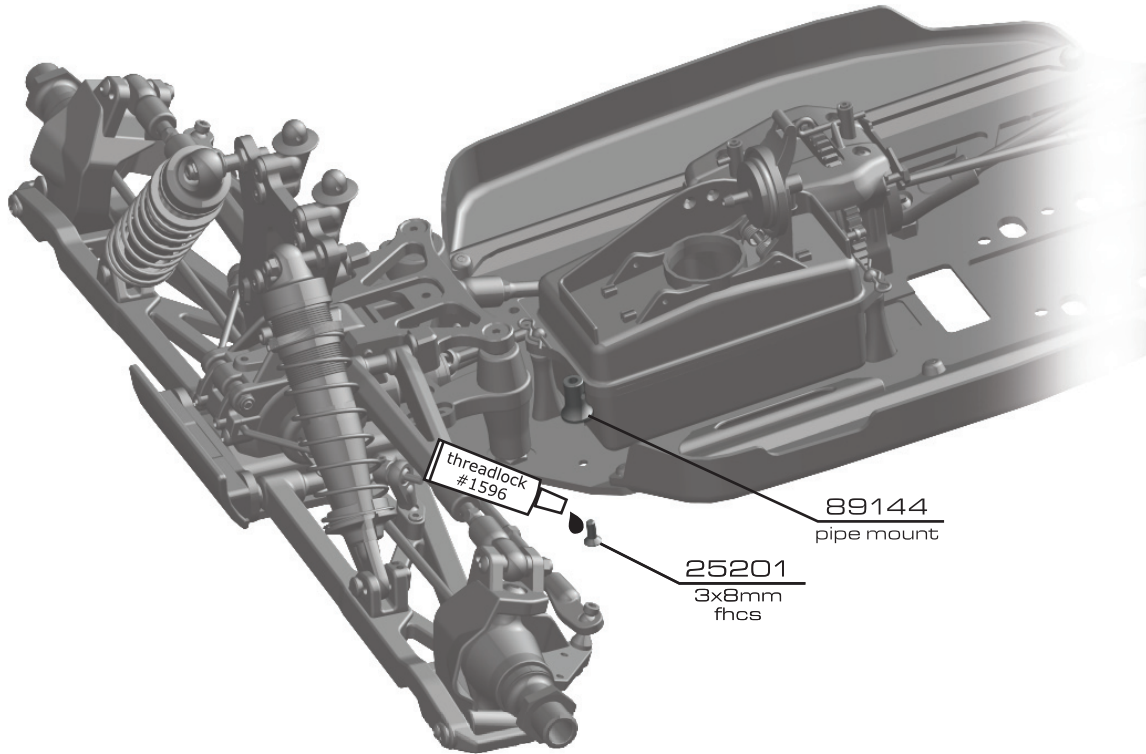

:: Chassis Assembly (cont.)

Bag K5

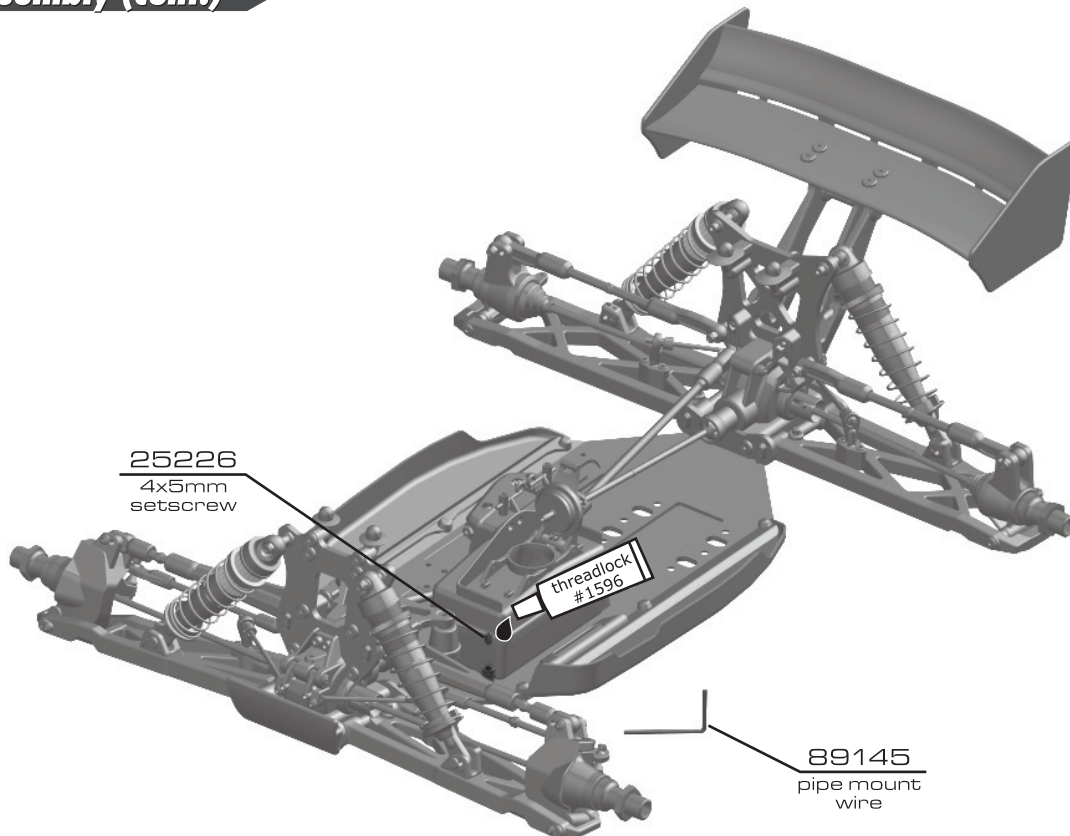

:: Chassis Assembly (cont.)

Bag K6

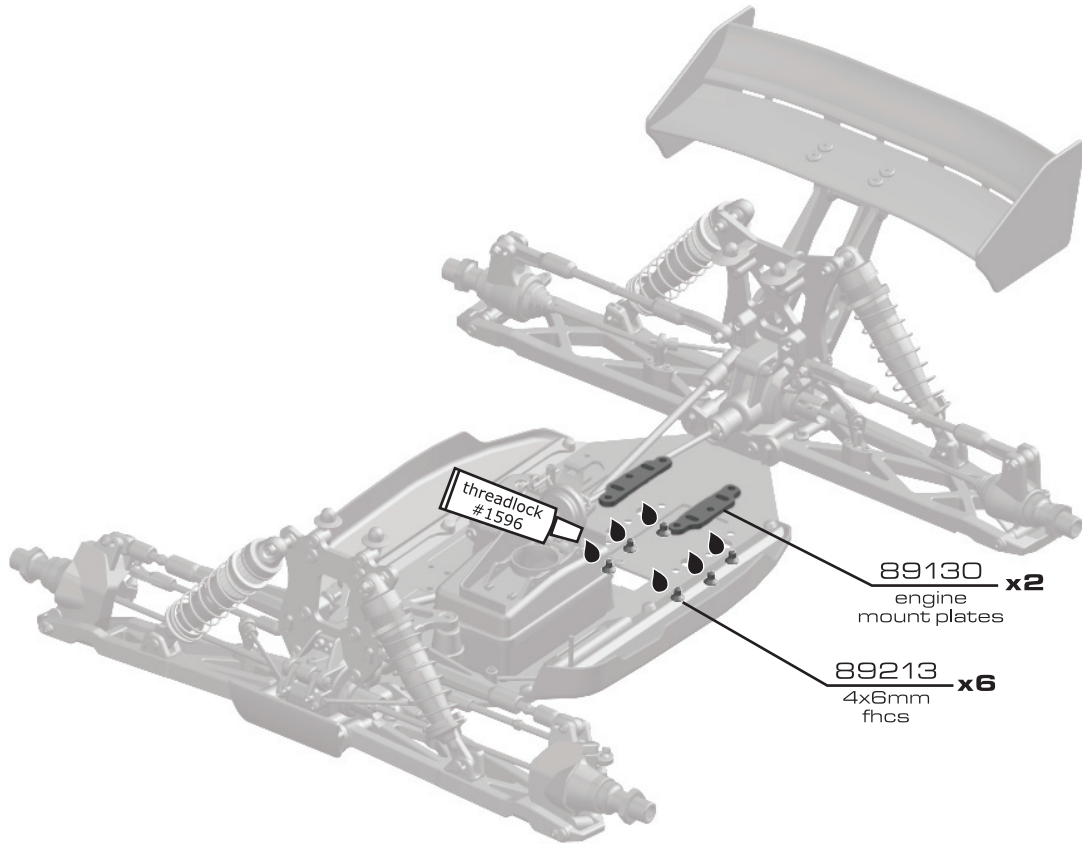

threadlock #1596

89130 x2
engine mount plates

89213 x6
4x6mm fncs

:: Radio Tray

Bag L1

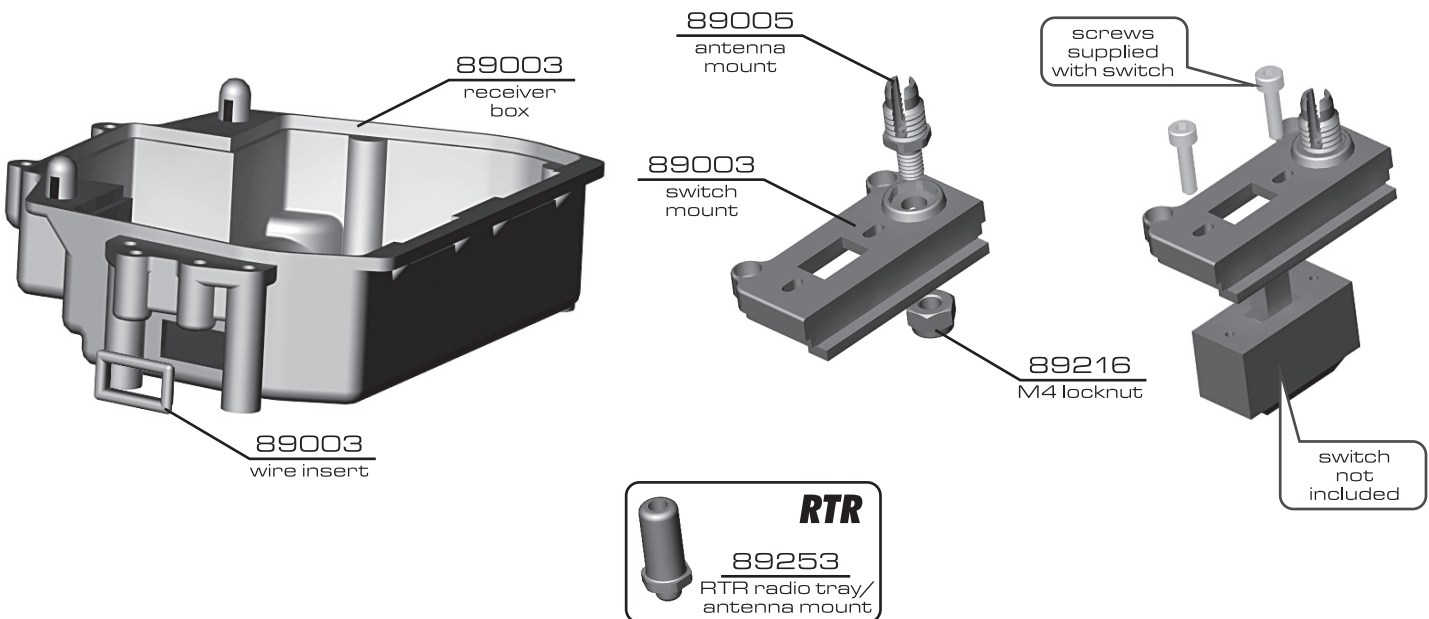

89003 receiver box

89005 antenna mount

screws supplied with switch

89003 switch mount

89216 M4 locknut

switch not included

89003 wire insert

RTR
89253 RTR radio tray/antenna mount

:: Radio Tray (cont.)

Bag L2

89222
2.5x8mm
shcs

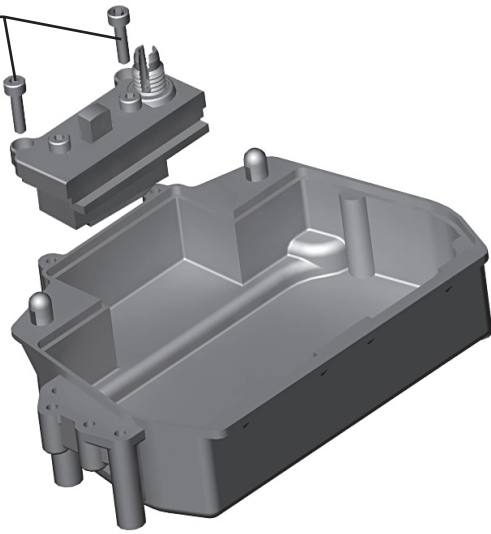

89004
receiver box
pad (lower)

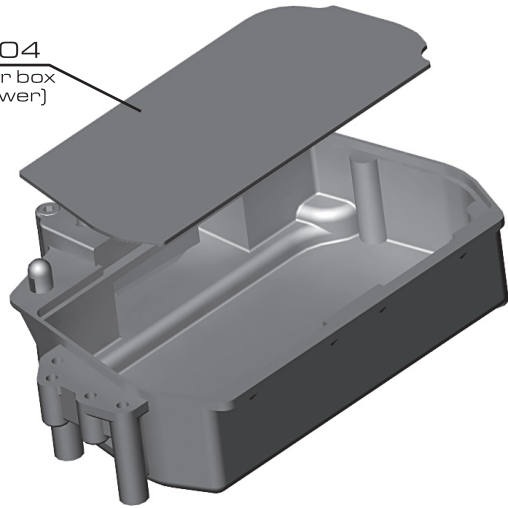

:: Radio Tray (cont.)

Bag L3

6338
antenna
tube
& cap



89005
antenna
mount nut

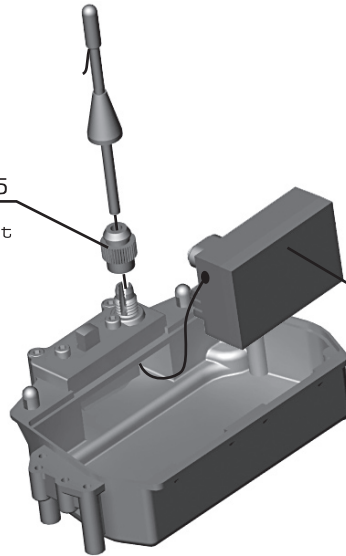

25203
3x12mm
fhcs x2

29164
XP3D
receiver
(RTR)

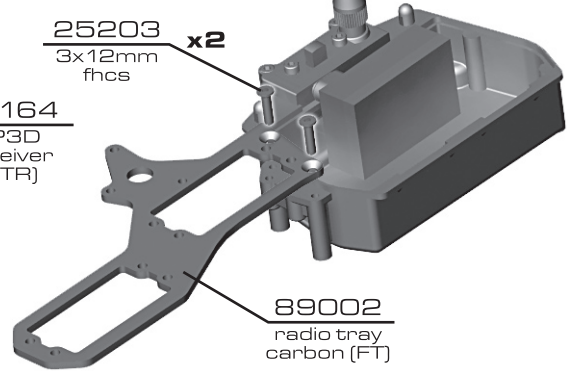

89005
antenna
boot

89002
radio tray
carbon (FT)

:: Radio Tray (cont.)

Bag L4

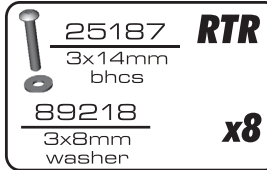

89209
3x18mm
fhcs x4

29126
S2008
hi-torque
servo (RTR)

89229
blue
countersunk
washer (FT) x4

89006
servo spacers
(1 thin, 1 thick)

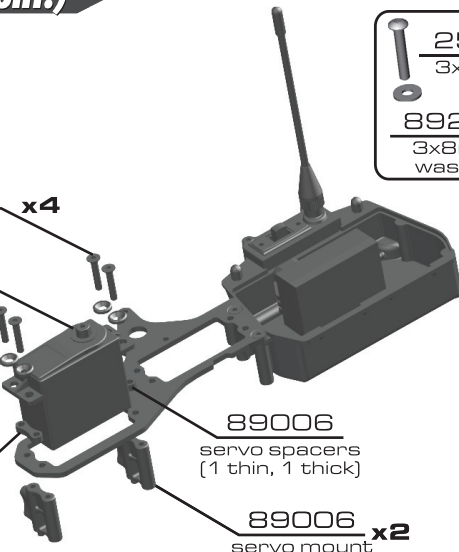

89006
servo spacers
(1 thin, 1 thick)

89006
servo mount x2

RTR

25187
3x14mm
bhcs

89218
3x8mm
washer x8

x8

89229
blue
countersunk
washer (FT) x4

89006
servo spacers
(1 thin, 1 thick)

89209
3x18mm
fhcs x4

89006
servo spacers
(1 thin, 1 thick)

29124
S1903MG
servo (RTR)

89006
servo mount

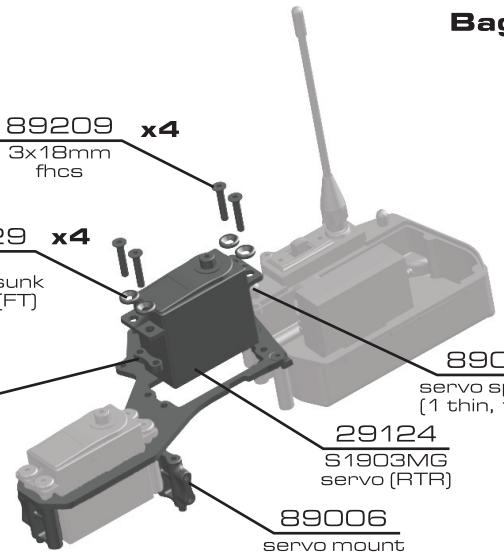

:: Radio Tray (cont.)

Bag L5

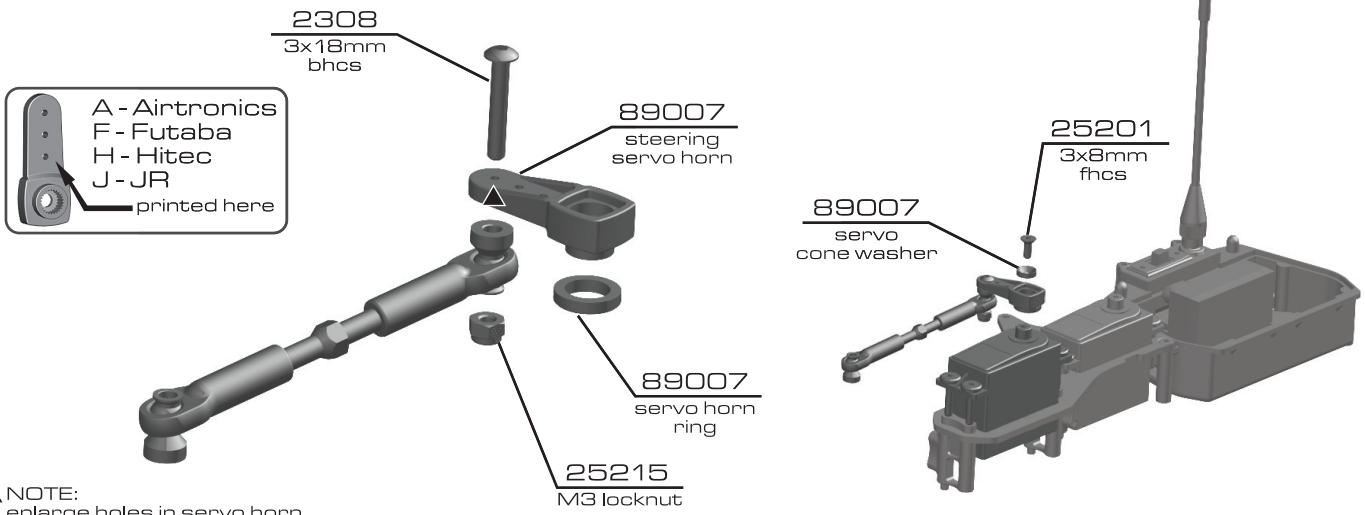

:: Radio Tray (cont.)

Bag L6

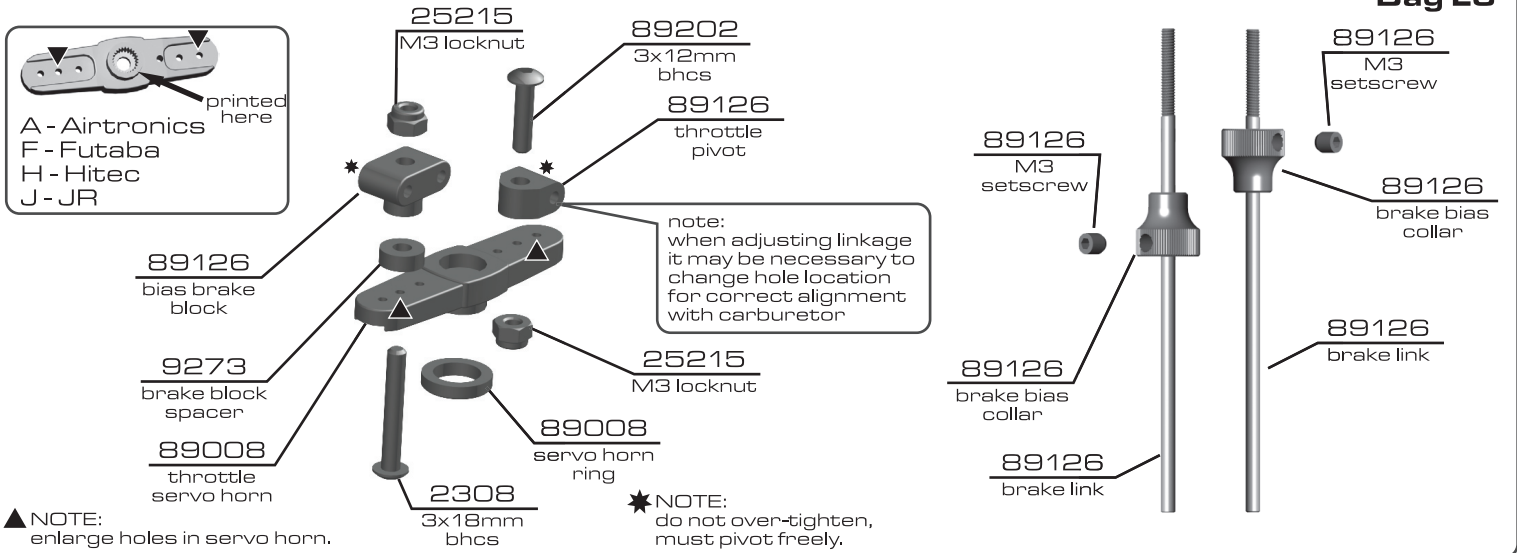

:: Radio Tray (cont.)

Bag L7

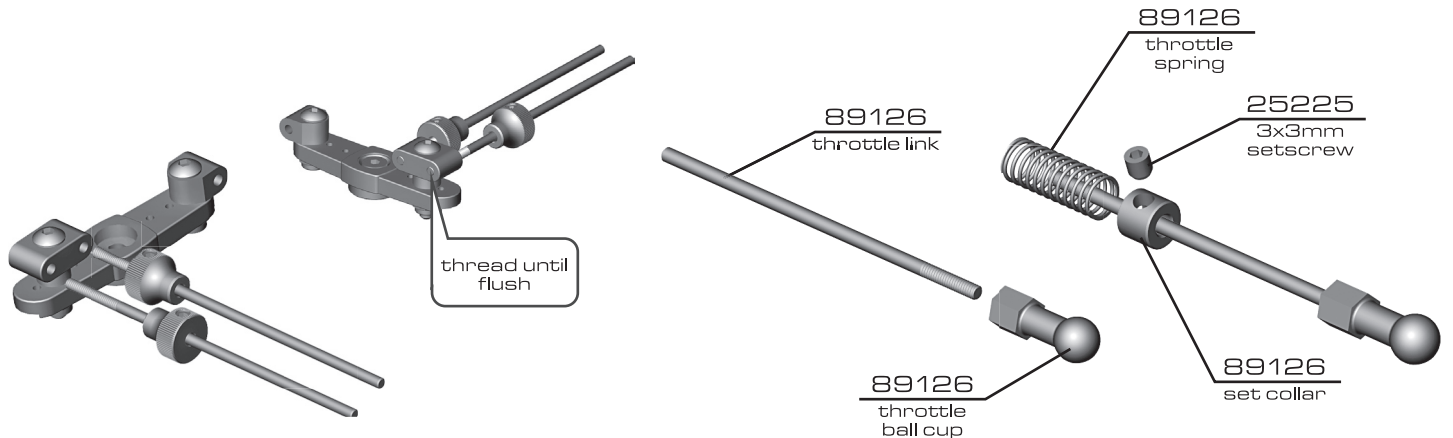

:: Radio Tray (cont.)

Bag L8

25225
3x3mm
setscrew

89126
brake bias
collar

25201
3x8mm
fncs

89008
servo
cone washer

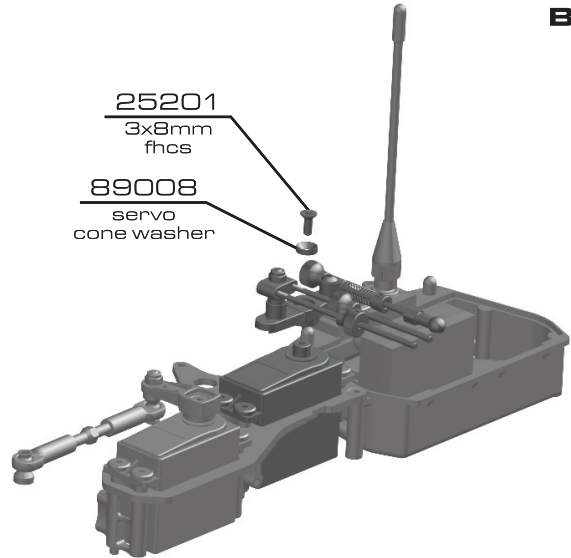
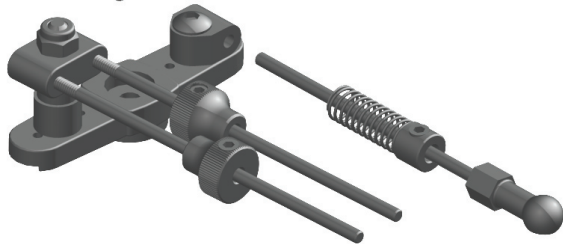

:: Radio Tray (cont.)

receiver pack configurations

*screws and
transponder
not included.

*receiver pack
not included

screw size
3x6mm

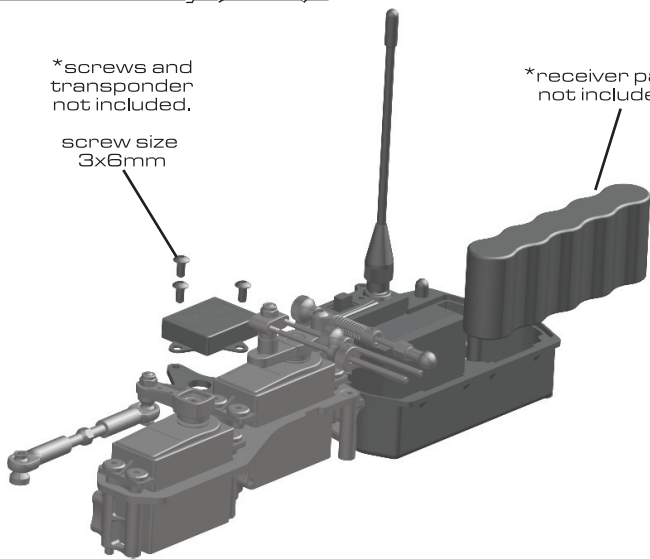

4 cell AA pack

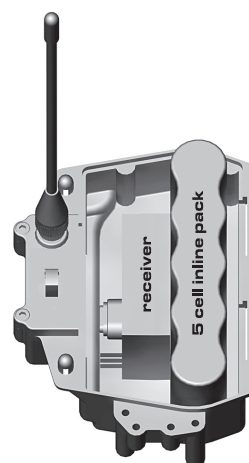

5 cell inline pack



5 cell hump pack

:: Radio Tray (cont.)

Bag L9

89003
battery box
top

89004
receiver box
pad (upper)

21173
small
body clip
x2

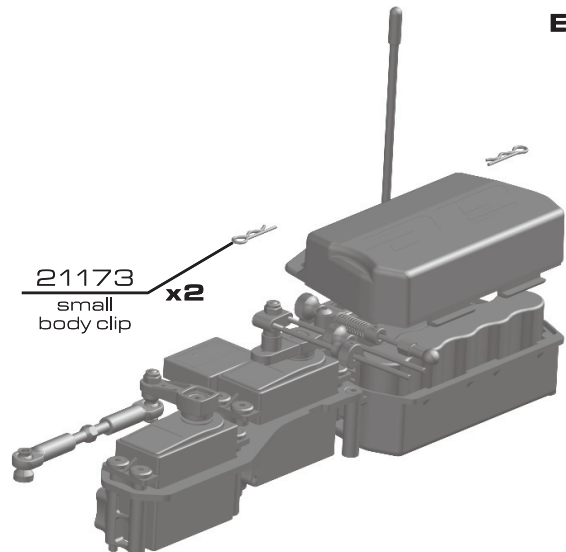
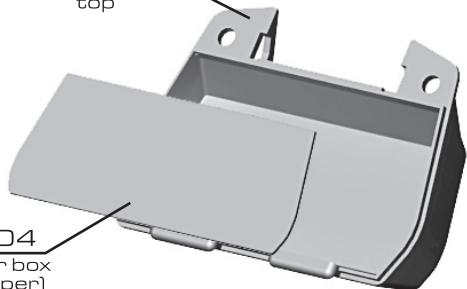

:: Radio Tray Assembly

Bag L10

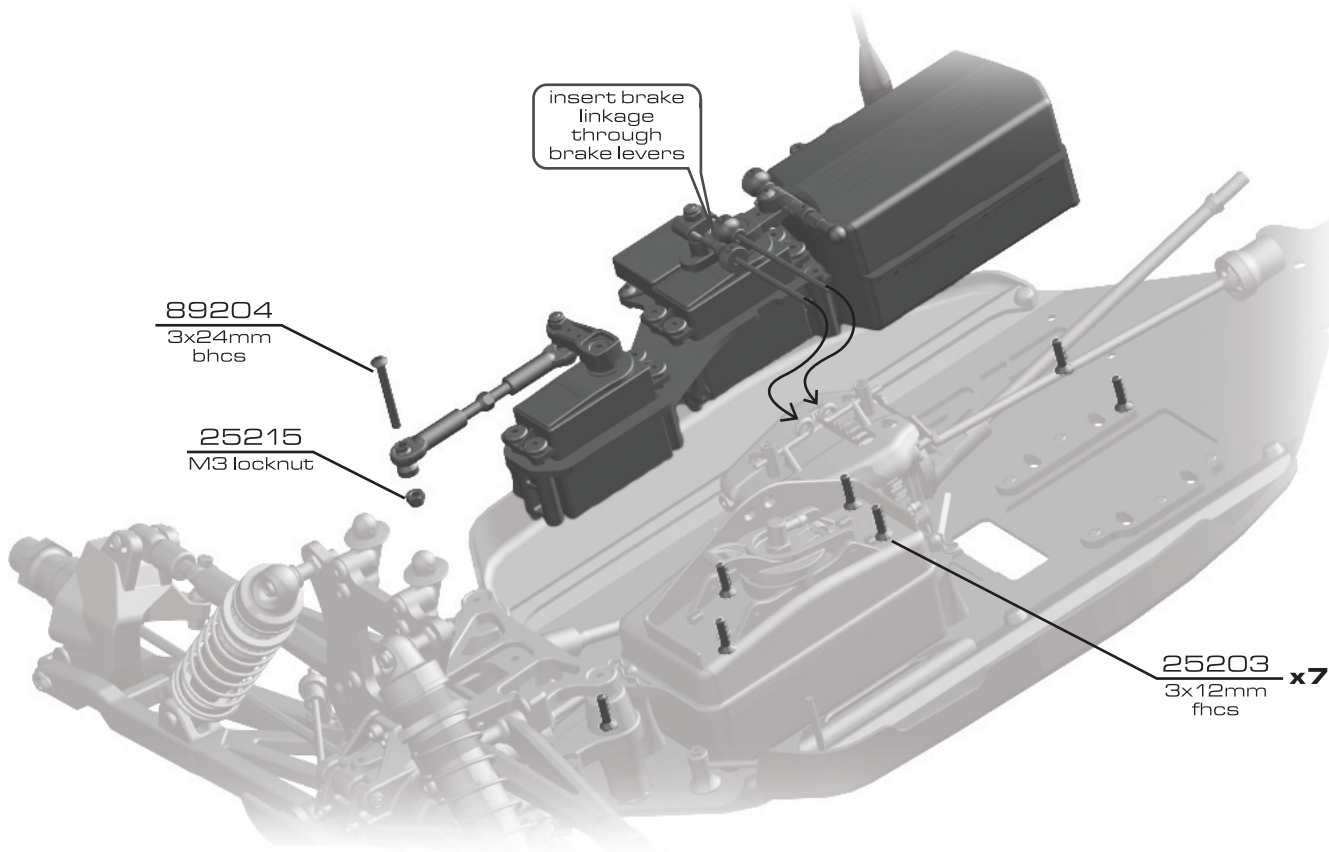

:: Radio Tray Assembly (cont.)

Bag L11

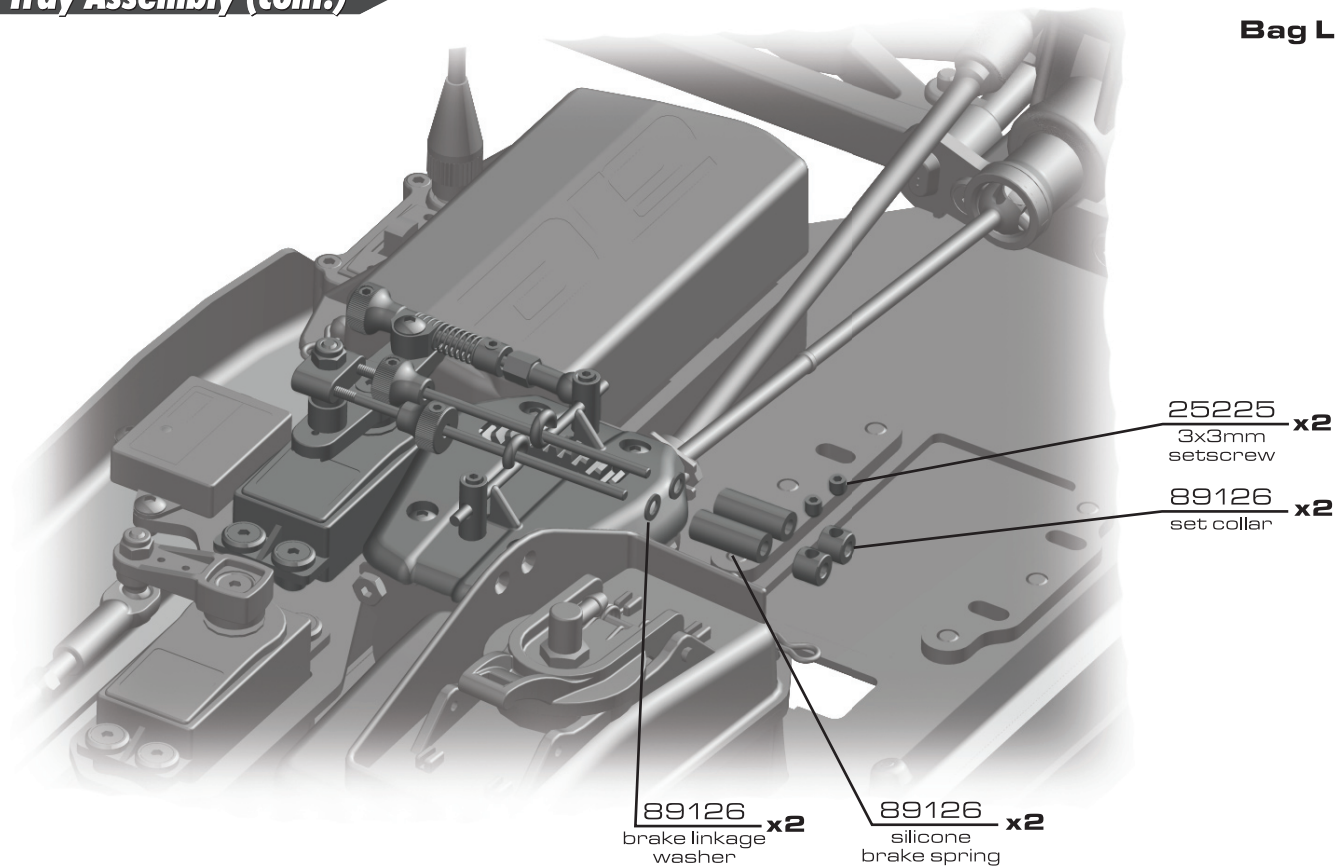

:: Engine

Bag M2

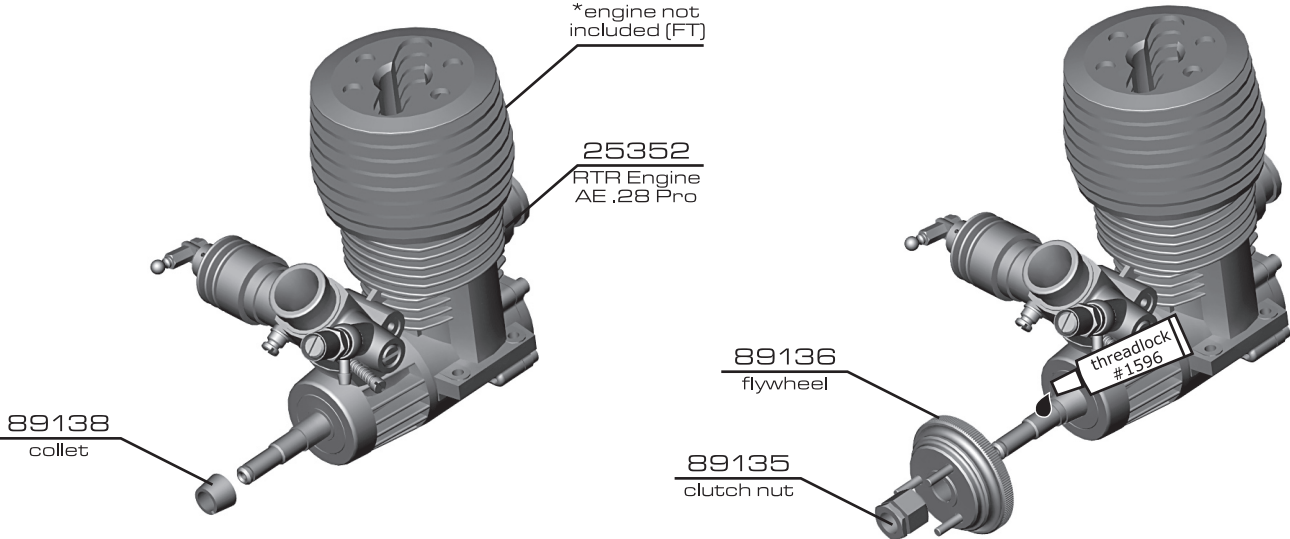

:: Engine (cont.)

Bag M3

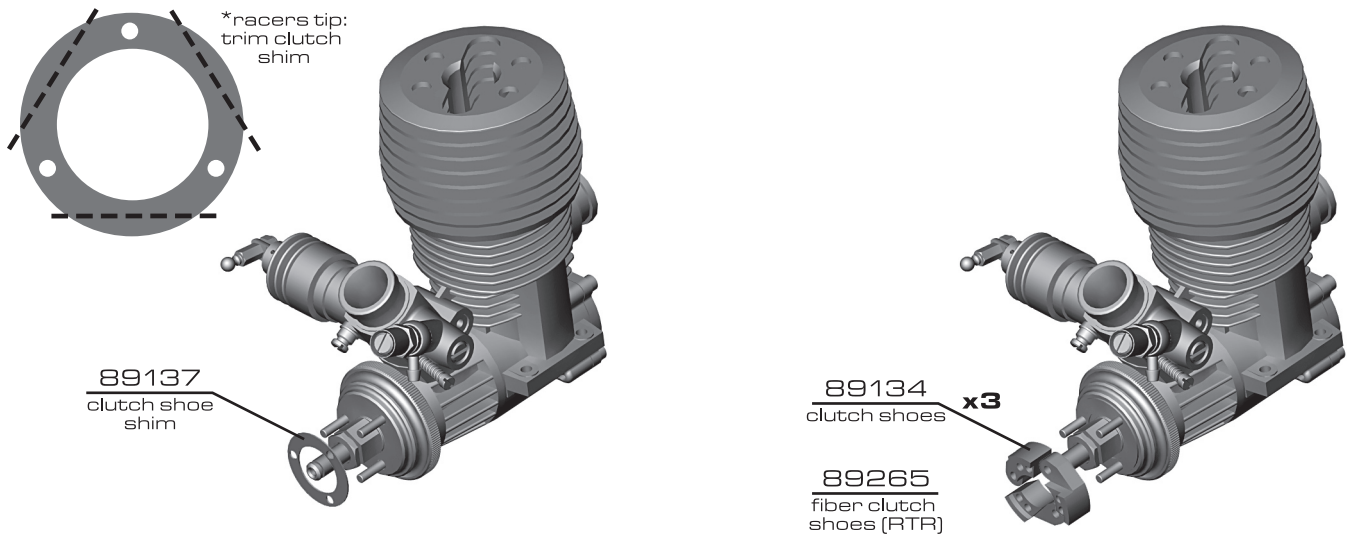

:: Engine (cont.)

Bag M4

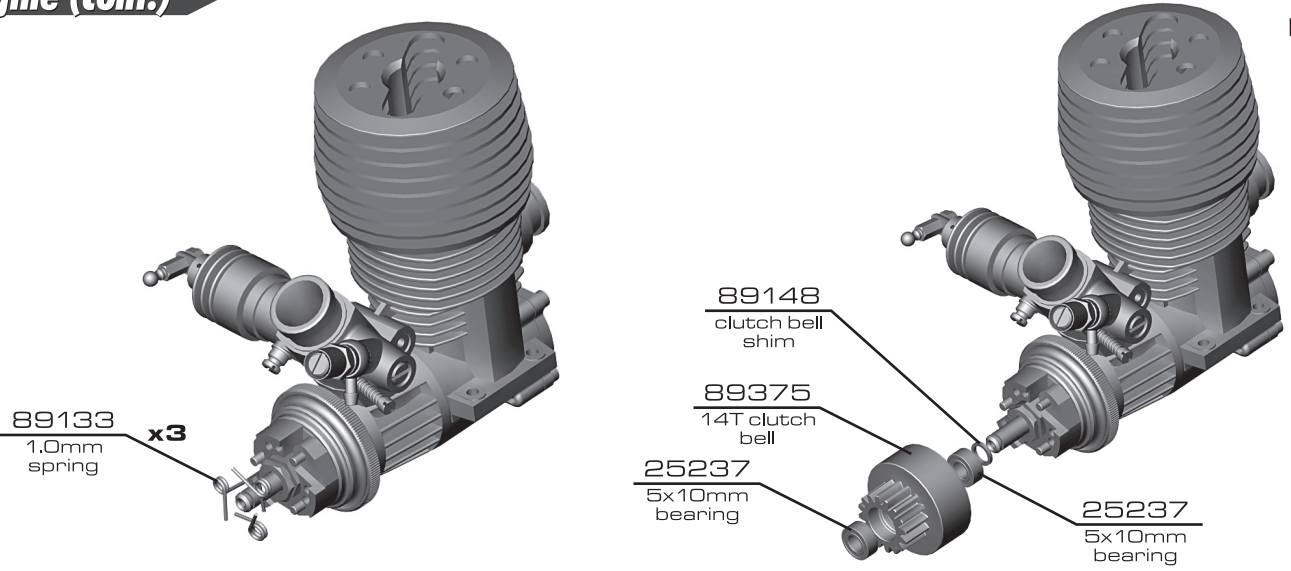

:: Engine (cont.)

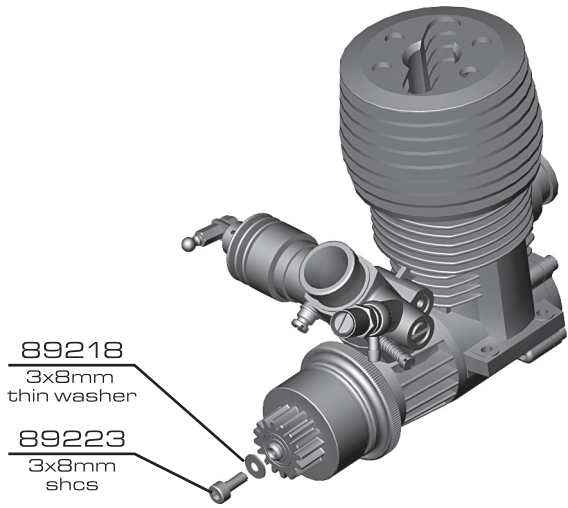

- 89218
3x8mm
thin washer
- 89223
3x8mm
shcs

clutch shimming instructions:
if assembly does not spin freely, use 89218 (small clutch shim) on screw to increase end play.

if crankshaft extends past clutch bearing, use 89218 (large clutch shim) to reduce end play.

Bag M5

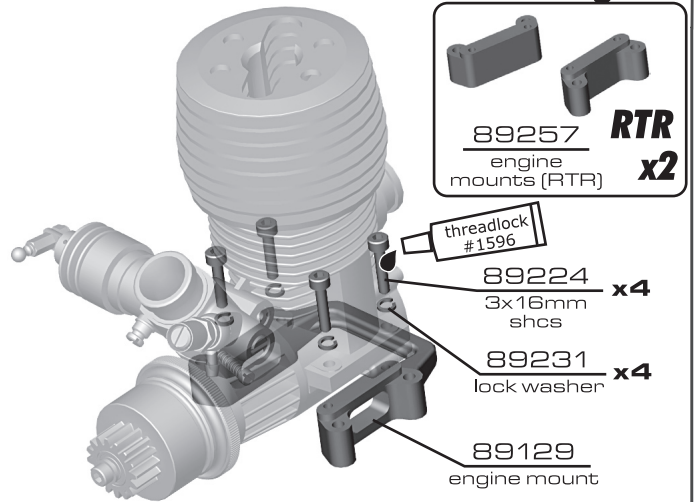

- 89257 **RTR**
engine
mounts (RTR) **x2**

- threadlock #1596
- 89224
3x16mm
shcs **x4**
- 89231
lock washer **x4**
- 89129
engine mount

:: Engine (cont.)

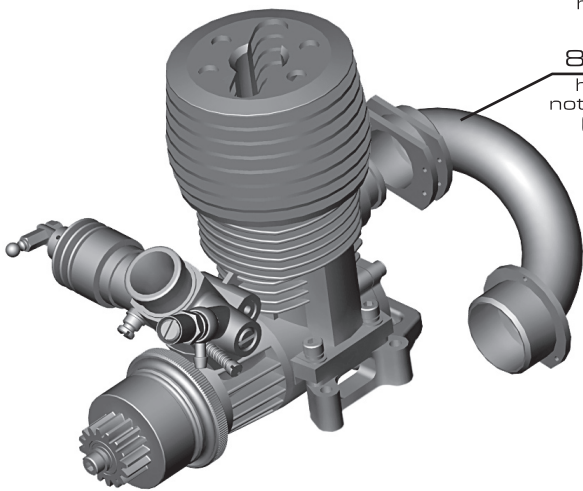

- 89274
header
(RTR)
- 89176
header,
not included
(black)

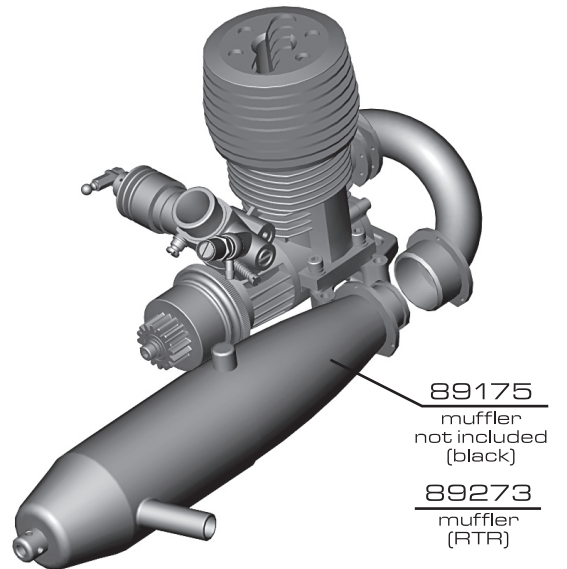

- 89175
muffer
not included
(black)
- 89273
muffer
(RTR)

:: Engine Assembly

Bag M6

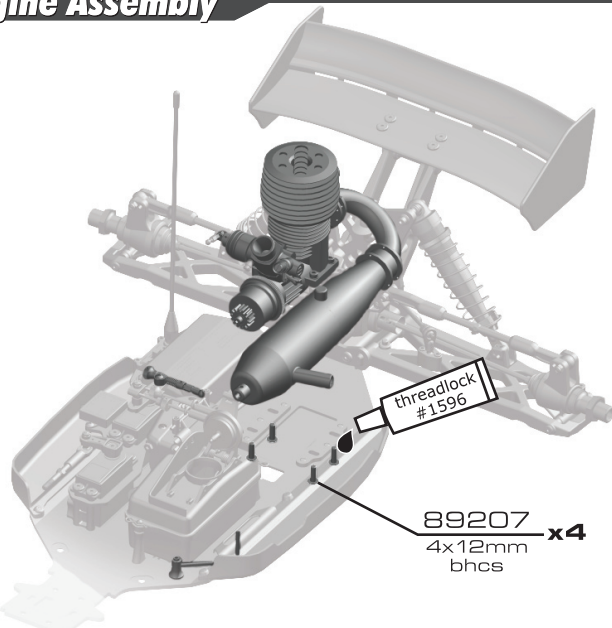

- threadlock #1596
- 89207 **x4**
4x12mm
bhcs

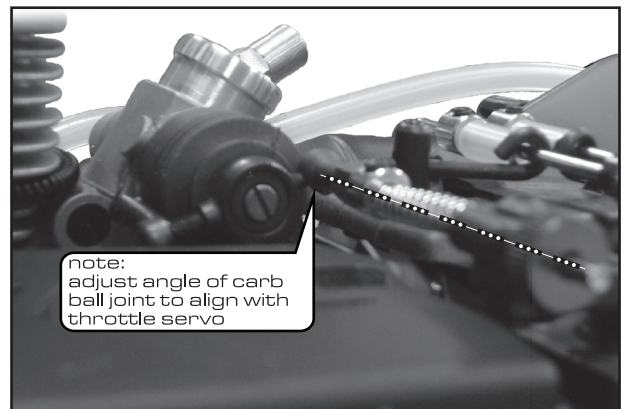

note:
adjust angle of carb
ball joint to align with
throttle servo

:: Linkage Adjustment

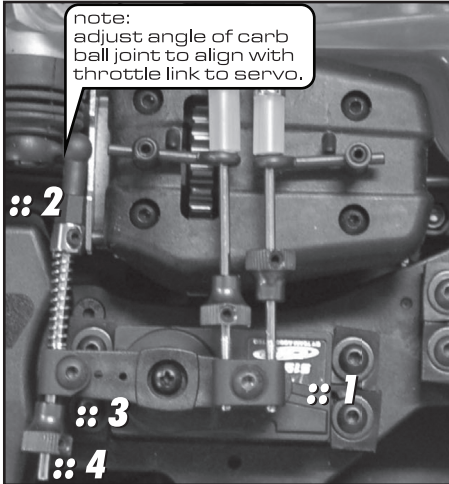

- 1: turn on transmitter and car. adjust servo horn until position is parallel with centerline at neutral.
- 2: set pre-load on spring so that throttle will close.
- 3: set .05mm gap on throttle collar.
- 4: trim off excess rod.

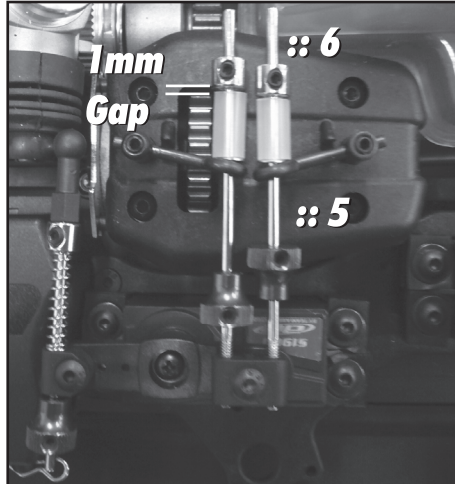

- 5: pull cams to engage brakes. set collar (with brakes engaged) to have 1 mm gap between tubing and collar. remember: transmitter is still on during this step.
- 6: trim off excess brake link wire.

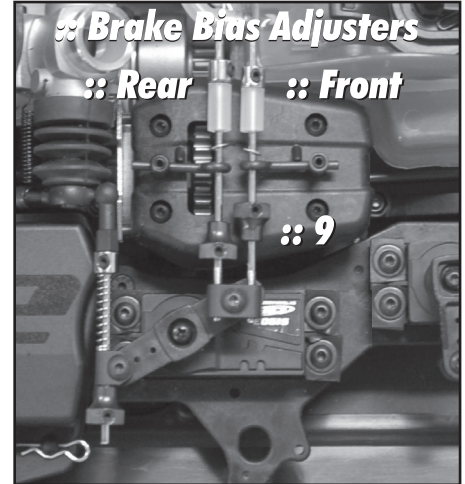

- 7: set throttle EPA max. apply full throttle on transmitter and set EPA so that the carb is full open. be careful not to over-extend the carb.
- 8: set max brake EPA at 30% as a starting point.
- 9: brake bias adjusters: thread the adjuster into the mount to achieve stronger brakes on that end of the car.

!DO NOT START ENGINE FOR THIS STEP!

:: Filter Assembly

Bag M7

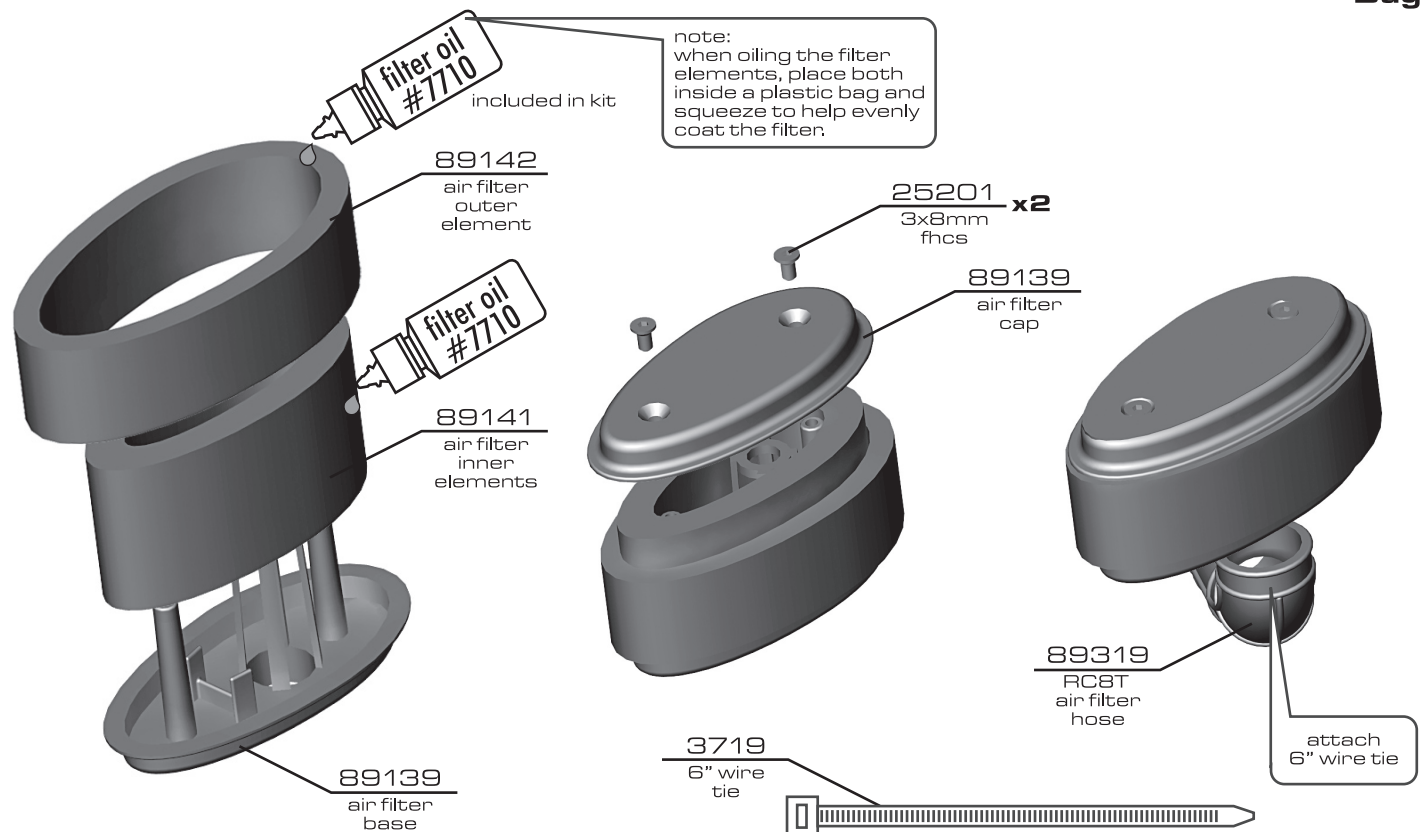

:: Filter Assembly (cont.)

Bag M7

3719
6" wire
tie



attach
6" wire tie

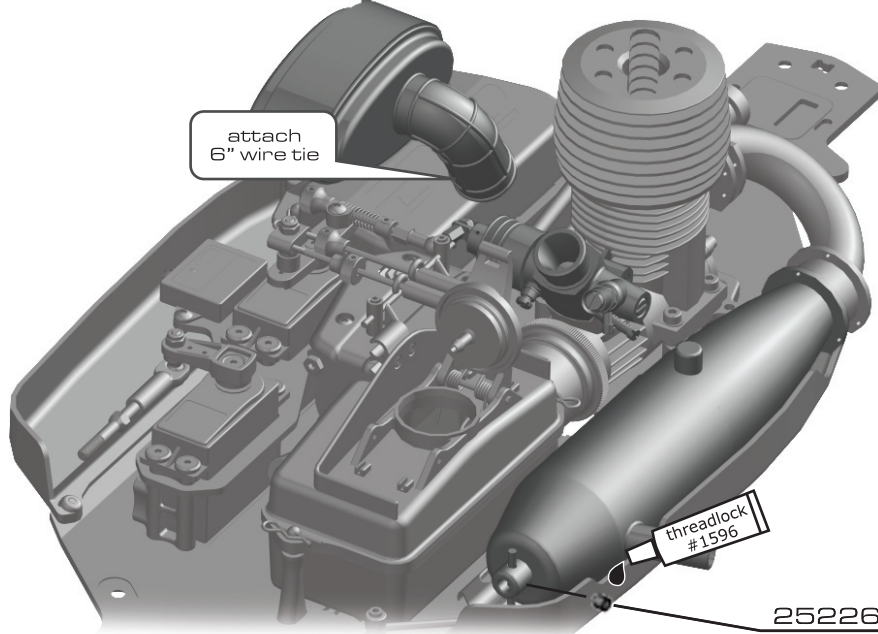

threadlock
#1596

25226
pipe hanger
set screw
not included

:: Fuel Line

Bag M1

—————
pressure line
from fuel tank lid to
exhaust pipe nipple

.....
fuel line
from fuel tank to
carburetor

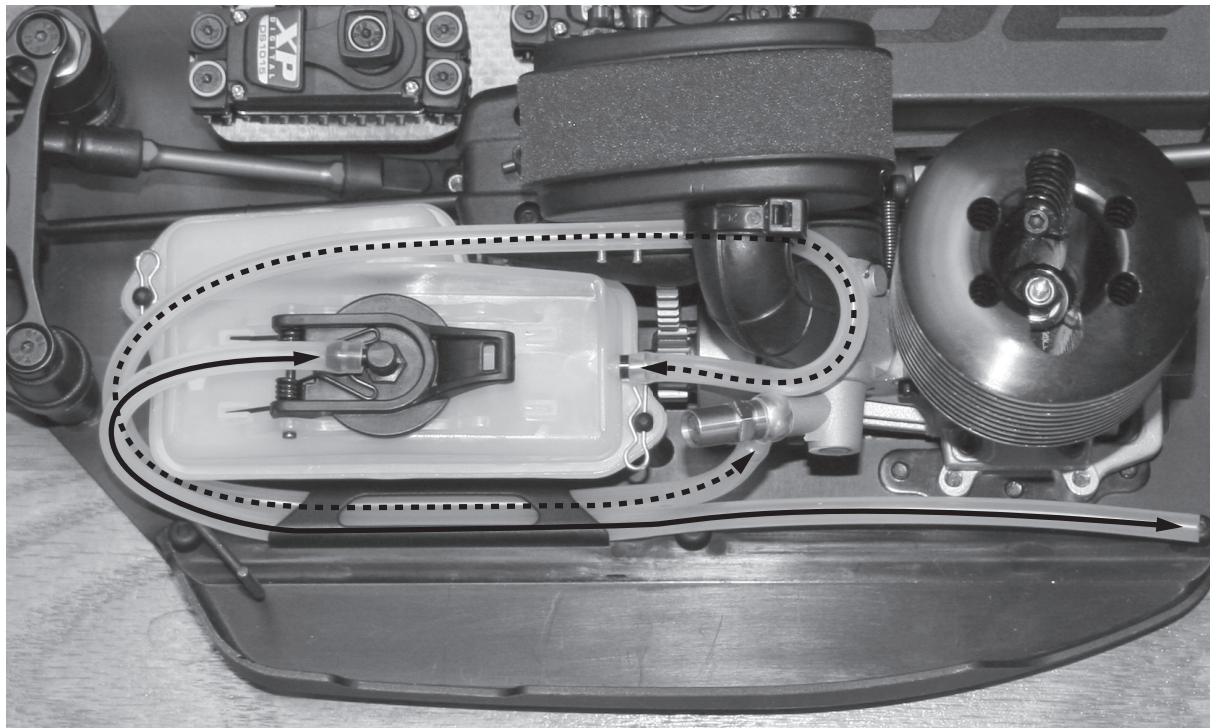

:: Fuel Line (cont.)

Bag M1

89326
2x4mm
fnps

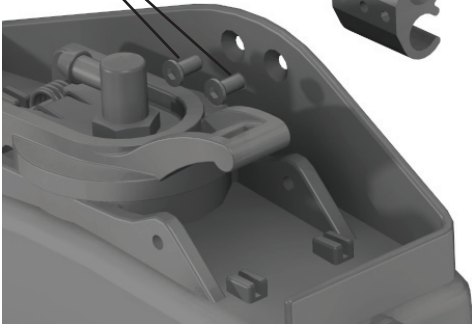

89325
fuel tubing
clip



89325
fuel tubing
clip

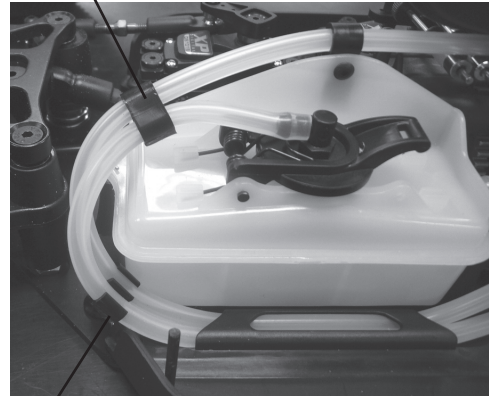

89325
fuel tubing
clip

:: Tire Assembly

Bag N1/N2

89252
wheel hex
nuts silver
(RTR)

89094
wheel
hex nuts

89383
pre-glued
wheel/tire
(RTR)



89383
pre-glued
wheel/tire
(RTR)



89360
AE wheel

89360
AE wheel

89094
wheel
hex nuts

89252
wheel hex
nuts silver
(RTR)

tires and
inserts not
included in
FT kit

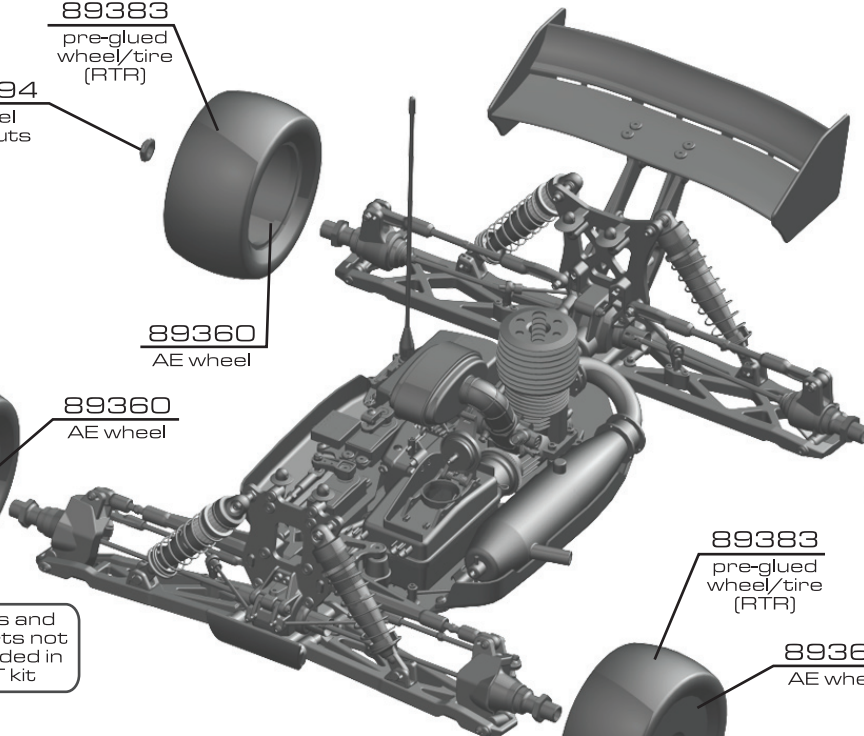

89383
pre-glued
wheel/tire
(RTR)

89360
AE wheel

89383
pre-glued
wheel/tire
(RTR)

89360
AE wheel

89094
wheel
hex nuts

89252
wheel hex
nuts silver
(RTR)

89094
wheel
hex nuts

89252
wheel hex
nuts silver
(RTR)

:: Body Assembly

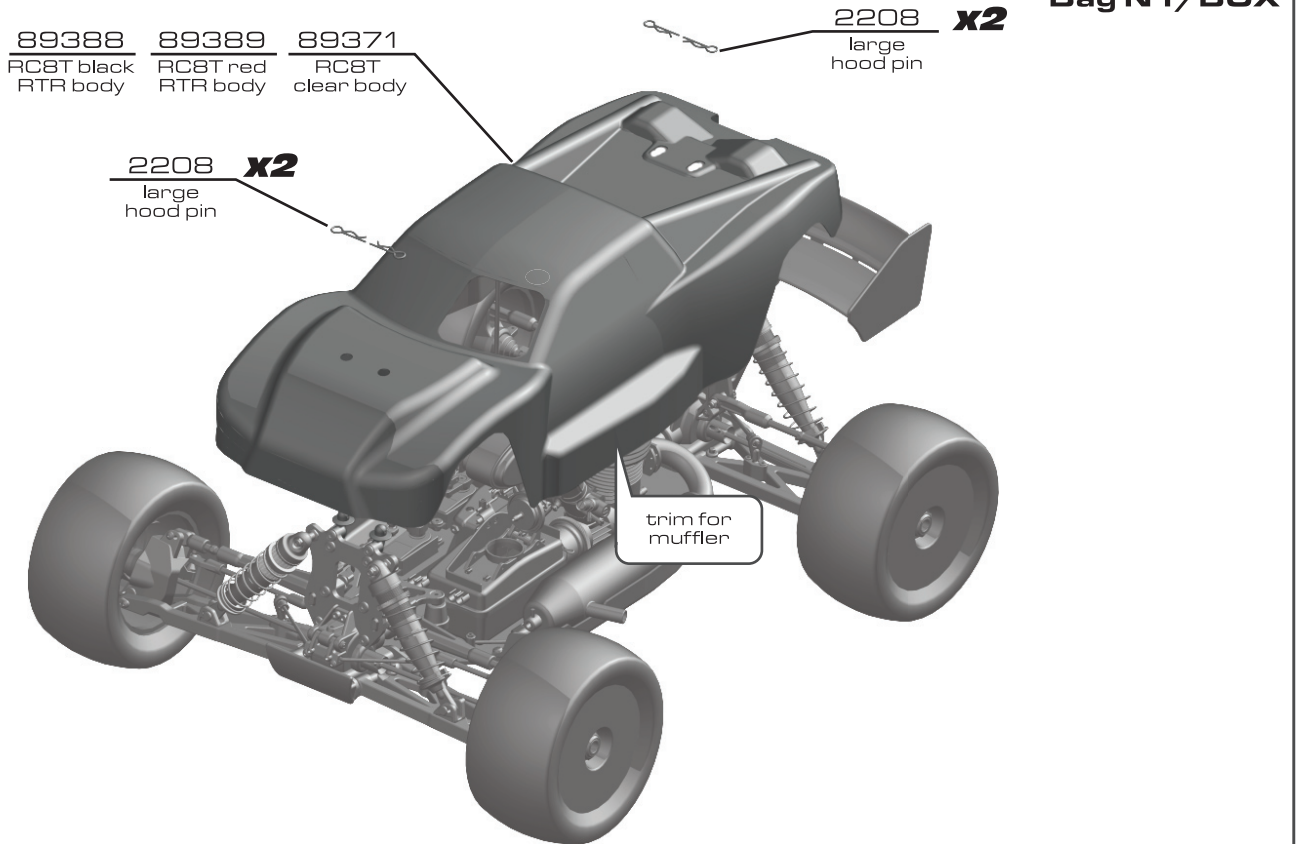

:: Building Tips

Tires:

The tires need to be glued to the wheels using any fast-curing FT Tire glue (CA) (AE Pt# 1597). This is available at your local hobby shop. Make sure to clean the mounting surface of the tire with alcohol for best adhesion

Gear Mesh:

To correctly set your gear mesh, follow the steps below:

1. Loosen engine mount screws so you can slide your engine and mount.
2. Slide engine and mount until the clutchbell gear comes in contact with the spur gear. Tighten engine mount screws. Hold the spur gear in place and 'rock' the clutchbell gear. There should be a little 'free-play' between the gears.
3. If you have a small amount of 'free-play', continue building your RC8T. If not, go back to Step 1.

Receiver Pack:

Your RC8T does not come with a receiver pack. It is recommended that you use a 5-cell 1000mah pack (minimum) in either stick (AE Pt #613) or hump (AE Pt#612) pack configuration (your RC8T will accept either). Charge your pack per the battery manufacturer's instructions. This will need to be done before you can setup up your RC8T. (RC8T RTR requires 4AA batteries for the included battery holder, or they can be replaced with #612 or #613 rechargeable receiver packs).

Engine Tuning:

Follow the manufacturers instructions to correctly tune your engine. You will need to adjust the fuel mixture according to altitude, weather, etc.

Clear Body (Factory Team only):

Your RC8T comes with a clear lexan body. You will need to prep the body before you can paint it. Wash the inside thoroughly with warm water and liquid detergent. Dry using a clean, soft, lint-free cloth. Use the supplied window masks to cover the windows from the **INSIDE** (RC cars get painted from the inside). Using high quality tape, apply to create a design to the inside of the body. Spray (either can or airbrush) the paint to the inside of the body (**NOTE: use ONLY paint that is recommended for use with lexan (polycarbonate) plastics. If you don't, you will destroy the plastic body!!!!**).

After painting, cut the body along the trim lines. Make sure to cut holes for the engine head, body mounts, antenna, fuel tank lid, top end adjustment needle and muffler outlet. Remove the clear protective sheet before applying decals.

:: Tuning**Gearing:**

Recommended Gearing: 14-54 This is a good starting point for most tracks.

When using a .28 size engine, the Team will typically change the spur gear to a 50 tooth. Other optional gearing for .21 on a smaller track will be 13-52 or 13-54.

Differential Fluid:

Team Associated includes a complete bottle of 7,000cst diff oil. You can also provide your own oil and try one of the optional setups.

Standard differential fluid setup: Front = 7,000cst; Center = 7,000cst; Rear = 7,000cst.

Optional diff setup 1 (bumpy outdoor track):

Front = 7,000cst; Center = 10,000cst; Rear = 3,000cst.

Optional diff setup 2 (high grip track):

Front = 10,000cst; Center = 15,000cst; Rear = 3,000cst.

Front Differential:

Use the standard setup for most cases. Try 10,000cst to 15,000cst to get less low speed steering and better acceleration out of turns.

Center Differential:

Use the standard setup for most cases. Many racers will try thicker oil (10,000 or 15,000cst) for harder acceleration out of turns.

Rear Differential: Start with the standard setup. For expert drivers, the most popular setting for truggy is 3,000 cst. the thicker 7,000cst kit oil will rotate less in the turns and accelerate straight on power. The thinner oil (2,000 or 3,000cst) will give more low speed traction.

Caster:

The supplied caster block inserts are 16 degrees. Standard kickup is 9 degrees (2 dot - up insert). You can reduce caster to 14 degrees for smoother steering (also adjust upper caster spacing with both shims in front of the ball joint) and up to 18 degrees for more steering (also adjust upper caster spacing with both shims behind the ball joint).

Front Upper Pivot Insert:

The standard insert is 2 dot - down. Going up (2 up, 3 up - 1 mm each) will give more turn in, but less steering on exit. going down (2 down, 3 down) will reduce turn in, but give more steering on exit.

Front Caster Block Location:

The standard long location will work the best for most tracks. going to the short front link will give you less steering, but can make the car more predictable in bumps and exiting turns.

Steering Rack Location:

The standard middle location will work the best for most tracks. Going to the back hole will give the car more aggressive steering, especially off-power at low speed. Going to the front hole will give more steering, especially noticeable on power through faster sweeping turns.

Front Camber:

A good starting camber setting is -2 degrees. Positive camber, where the top of the tire is leaning out, is typically not recommended.

Front Toe-In:

Zero degree toe-in (tires pointing straight forward) is a good starting setting. You can increase turn in by adding 1-2 degrees of toe-out (front of tires point slightly out). Front toe - in is not a typical tuning adjustment used by the Team.

:: Tuning (cont.)**Front Ride Height:**

The front ride height setting you should use most often is with 37mm of gap between the chassis bottom and the ground. Check the ride height with the FT Ride Height Gauge (# 1449) by lifting up the entire car about 8-12 inches off the bench and drop it. After the suspension "settles" into place, then raise or lower the adjustment collars as necessary.

Front Arm Hole Shockmount:

Inside on the arm will give a more responsive front end. Outside on the arm will be less responsive steering, but will be more predictable through bumps.

Anti-squat:

Anti-squat denotes the angle of the rear arms relative to the ground. The kit setting is 2 degrees, and you can also run 1 degree by changing to 3 DOWN insert in front of the rear gearbox. Run the 1 dot insert to get 3 degrees of anti-squat. Less antisquat lets the suspension work more over the bumps, but it will sacrifice the ability to square up on power.

Rear Camber Link Length & Vertical Adjustment:

On the RC8T you can change the length of the camber link on the hub, or adjust the inboard location on the tower. The longer link will give the feeling of the most grip, but it will not be as responsive to square up on throttle, and might get loose if the truggy is driven hard. This can easily be corrected by running the shorter link on the hub, but it will sacrifice some forward grip.

Changing to a higher location on the tower will be a smaller adjustment than changing the length of the upper link. Going up on the tower location has a similar effect as the longer link, but not as drastic. For example, if you change to the short rear link on the hub and you need to gain more forward grip, try raising the link up on the tower.

Rear Hub Hinge Pin Height:

The kit setting of the upper hole gives more rear grip on turn in, and good forward traction, but it might have difficulty squaring up out of turns. Changing to the lower hinge pin hole in the hub is one of the best adjustments to make to the rear end, more responsive on throttle, and to give more side grip in the turns.

Rear Hub Spacing:

You have 3 options for rear hub spacing, FWD, MIDDLE, & BACK. The kit setting provides a good balance of rear traction and steering, and will be used most often. Moving the hubs FWD will give more rear traction for low grip tracks. You can use the hubs BACK on high grip tracks. Also, you can replace the included shims to get intermediate settings.

Rear Camber:

A good starting camber setting is -2 degrees. Use the included # 1719 camber gauge to set your camber. Adding a small amount of positive camber, where the top of the tire is leaning out, will tend to improve straight-line acceleration on loose tracks.

Rear Ride Height:

The rear ride height setting you should use most often is with 42mm of gap between the chassis bottom and ground. Check the ride height with the FT Ride Height Gauge (# 1449) by lifting up the entire truck about 8-12 inches off the bench and drop it. After the suspension "settles" into place, then raise or lower the adjustment collars as necessary.

Rear Arm Hole Shockmount:

Inside on the arm will give less entry steering, accelerates better straightline through bumps, but may lack side bite. Outside on the arm will be less grip, more steering, but will be more predictable when it breaks traction.

:: Tuning (cont.)

Droop Settings:

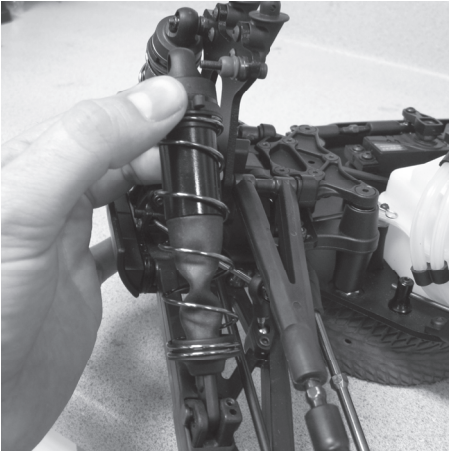

Step 1: With only the bottom of the shocks attached, the droop screws tightened all the way, and the chassis above your working surface so the arms are at full extension, you should be able to easily slide the top of your shock over the standoff screw, while leaving the shock at full extension. If the mounting hole of the shock cap is above or below the standoff screw, adjust the droop screw accordingly. Repeat for all corners of your vehicle. Measure from the center of the standoff screw to the center of the shock riser button to get your FULL DROOP setting. The front shocks should be 115mm, while the rear shocks should be 126mm.

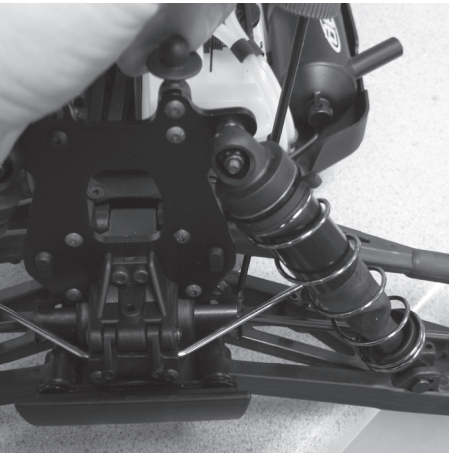

Step 2: Finish installing the shock to the standoff. Set your vehicle to your desired droop setting. To increase your droop turn the droop screw (from the top) counter-clockwise (loosen), turn the droop screw (from the top) clockwise (tighten) to decrease your droop. Remember, never back the screw out beyond full droop or you could risk damage to your vehicle.

Front Droop: Increasing front droop (loosen droop screws) will increase off-throttle steering. It also allows the front end to lift more, giving more rear grip and less front grip on-power. Remember to never loosen the screws beyond the FULL DROOP setting. Decreasing front droop (tighten droop screws) yields more on-power steering and quicker response at the expense of some stability in bumpy sections. It will also give less off-throttle steering.

Rear Droop: Increasing rear droop (loosen droop screws) will increase traction in bumpy sections, but will reduce high-speed stability. Remember to never loosen the screws beyond the FULL DROOP setting. Decreasing rear droop (tighten droop screws) will increase stability in high speed sections, but will reduce stability in bumpy sections.

Setup Sheets:

Most often, the best way to get your car handling right is to go to our web site www.rc10.com and click on the Support link, then the Setup Sheets link, then RC8T setups. Our team of professional drivers help develop these setups at National events. Also, most drivers have a "base" setup that they use as a starting point for every event. Try running some of our base setups OR look for track conditions and tires that are similar to your local track and mimic that setup. Remember, each adjustment has a purpose, so copy everything from the setup sheet and then make adjustments based on the recommendations in here and in our online tuning guide at <http://www.rc10.com/rc/tuning>.

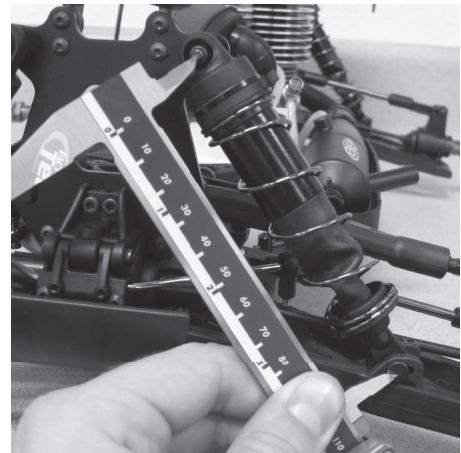
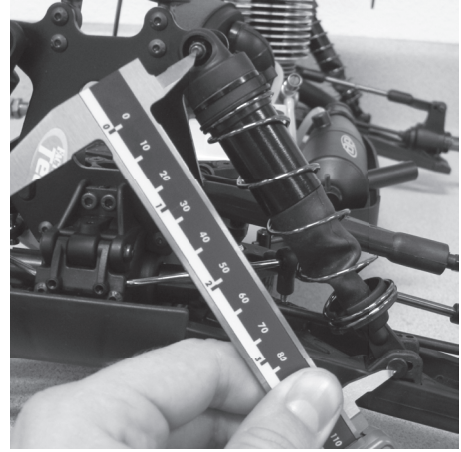

Step 4: Measure from the center of the shock standoff screw to the center of the shock riser button to get your final droop setting. The front shocks should both be set at the same length, as should the rear shocks. * The normal droop setting is between 0-5mm from the FULL DROOP measurement.

Setup Sheet for Team Associated's RC8T

Rev. 1

:: Front Suspension

anti-roll bar:
 2.2 - black
 2.5 - silver
 2.8 - gold

steering rack:
back
mid
front

hinge pin bushing
2
 up down

camber: -2 °

caster: 16 °

toe: 0 °

kickup bushing
2
 up down

ride height: 37mm

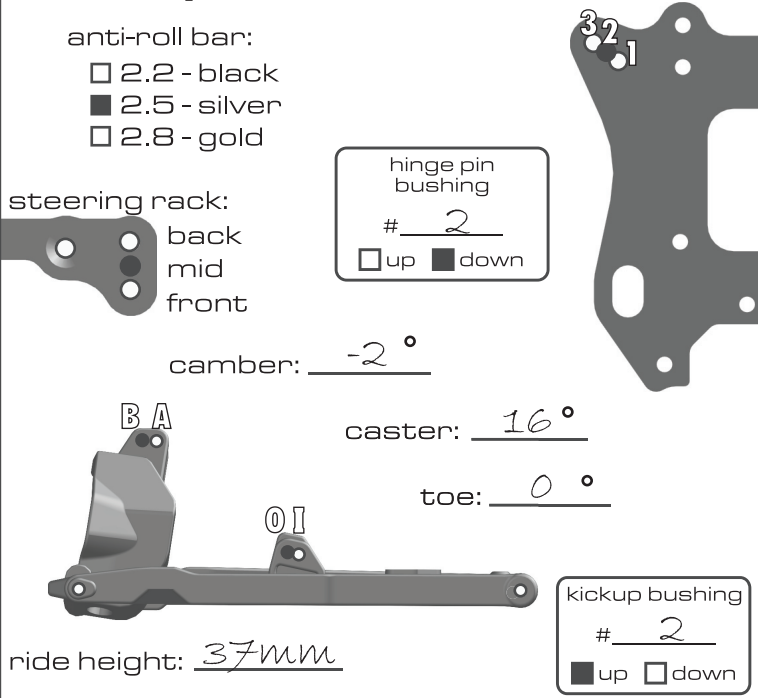

:: Rear Suspension

anti-roll bar:
 2.2 - black
 2.5 - silver
 2.8 - gold

wheelbase:
 long
 medium
 short

camber: -2 °

toe: 3 °

hub:
upper
lower

ride height: 43mm

anti-squat bushing
2
 up down

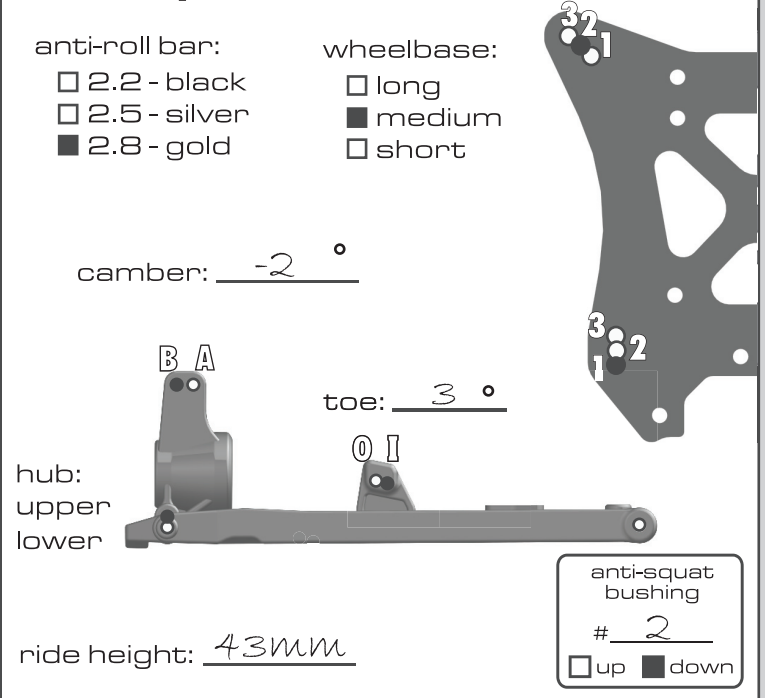

:: Front Shocks

spring: (5.1 lb) silver piston: 1.3
shock fluid: 50 wt. length: 113mm
shock cap: _____

:: Rear Shocks

spring: (3.3 lb) silver piston: 1.3
shock fluid: 50 wt. length: 125mm
shock cap: _____

:: Differentials

front fluid: 7000cst
center fluid: 7000cst
rear fluid: 7000cst

:: Wing

location: forward back
angle: low med. high
type: _____

:: Chassis Braces

standard molded aluminum
other: _____

:: Engine

engine: 30% recommended restrictor: _____
muffler: _____ temp: _____
glow plug: _____
fuel: _____

:: Gearing/Clutch

gearing: 14/54
shoes: 3 x aluminum _____ x fiber
spring: _____ x .9mm 3 x 1.0mm _____ x 1.1mm
notes: _____

:: Notes

:: Tires

tire (F/R): _____ / _____
compound (F/R): _____ / _____
insert: _____ wheel: _____

:: Race and Vehicle Comments









qualify: _____ main: _____ finish: _____ tq:
comments: _____

:: Track Info





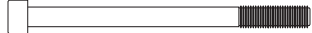





traction: high med. low
surface: smooth bumpy
 blue groove soft dirt grass
 clay wet dusty
other: _____

:: Hardware - 1:1



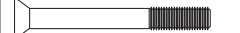









cap head (shcs)

-  2.5x8mm (89222)
-  3x8mm (89223)
-  3x10mm (25620)
-  3x16mm (89224)
-  3x20mm (25192)
-  3x24mm (89225)
-  3x26mm (89226)
-  3x40mm (89228)
-  3x45mm (89279)





flat head (fhcs)

-  3x8mm (25201)
-  3x10mm (25202)
-  3x12mm (25203)
-  3x14mm (89208)
-  3x18mm (89209)
-  3x20mm (89210)
-  3x26mm (89211)
-  3x30mm (89212)
-  4x6mm (89213)
-  4x12mm (89214)
-  4x14mm (89217)





button head (bhcs)

-  2.5x3mm (89201)
-  2.5x6mm (31520)
-  3x6mm (31531)
-  3x10mm (25211)
-  3x12mm (89202)
-  3x14mm (25187)
-  3x16mm (89203)
-  3x18mm (2308)
-  3x20mm (25188)
-  3x24mm (89204)
-  3x26mm (89205)
-  4x10mm (89206)
-  4x12mm (89207)



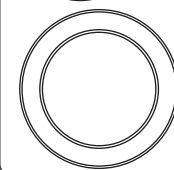

setscrews

-  3x3mm (25225)
-  3x5mm (89219)
-  4x5mm (25226)
-  4x12mm (89220)
-  5x4mm (89221)

ball bearings

-  steering bearing (89161)
-  5x10mm (25237)
-  6x10mm (31404)
-  8x16mm (25236)
-  15x21mm (89162)

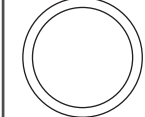
shims & washers

-  3x8mm thin washer (89218)
-  clutch bell shims (89148)
-  diff washer (89120)
-  diff shim (89117)
-  Blue countersunk washer (89229)
-  Silver cone washer (89230)

nuts (lock/plain)

-  m3 locknut (25215)
-  flanged m3 locknut (25612)
-  m4 locknut (89216)

notes

Setup Sheet for Team Associated's RC8T

Rev. 1

:: Front Suspension

anti-roll bar:

2.2 - black
 2.5 - silver
 2.8 - gold

steering rack:

back
 mid
 front

camber: _____

caster: _____

toe: _____

ride height: _____

hinge pin bushing

up down

kickup bushing

up down

:: Rear Suspension

anti-roll bar:

2.2 - black
 2.5 - silver
 2.8 - gold

wheelbase:

long
 medium
 short

camber: _____

toe: _____

ride height: _____

anti-squat bushing

up down

hub: upper lower

:: Front Shocks

spring: _____ piston: _____

shock fluid: _____ length: _____

shock cap: _____

:: Rear Shocks

spring: _____ piston: _____

shock fluid: _____ length: _____

shock cap: _____

:: Differentials

front fluid: _____

center fluid: _____

rear fluid: _____

:: Wing

location: forward back

angle: low med. high

type: _____

:: Chassis Braces

standard molded aluminum

other: _____

:: Engine

engine: _____ restrictor: _____

muffler: _____ temp: _____

glow plug: _____

fuel: _____

:: Gearing/Clutch

gearing: _____

shoes: _____ x aluminum _____ x fiber

spring: _____ x .9mm _____ x 1.0mm _____ x 1.1mm

notes: _____

:: Notes

:: Tires

tire (F/R): _____ / _____

compound (F/R): _____ / _____

insert: _____ wheel: _____

:: Race and Vehicle Comments

qualify: _____ main: _____ finish: _____ tq:

comments: _____

:: Track Info

traction: high med. low

surface: smooth bumpy

blue groove soft dirt grass

clay wet dusty

other: _____



Associated Electrics, Inc.
26021 Commercentre Dr.
Lake Forest, CA 92630 USA
<http://www.TeamAssociated.com>
<http://www.RC10.com>