

F-50R

FOUR-STROKE GASOLINE ENGINE

Operating Instructions

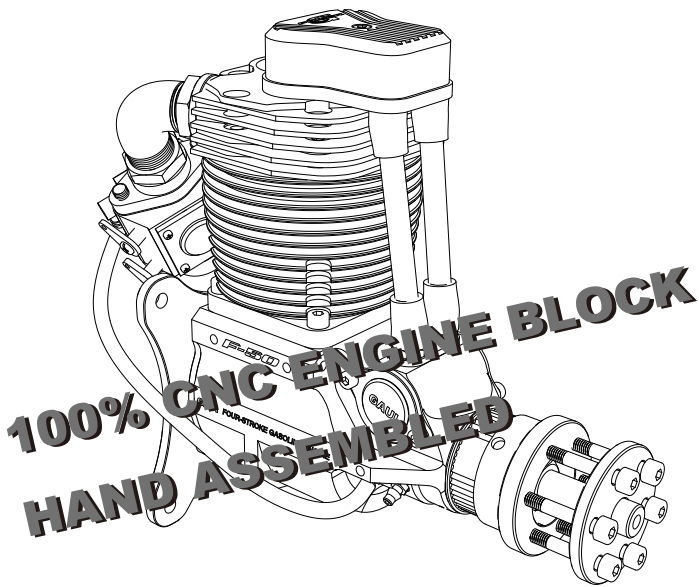

Specifications :

Displacement : 49.87cc
Practical rpm : 1200~7000rpm
Suggested Props : 20~21X10
20X10≐6800rpm
Gasoline/Oil Mix : 20:1
Weight : 1500g

WWW.GAUIGPOWER.COM

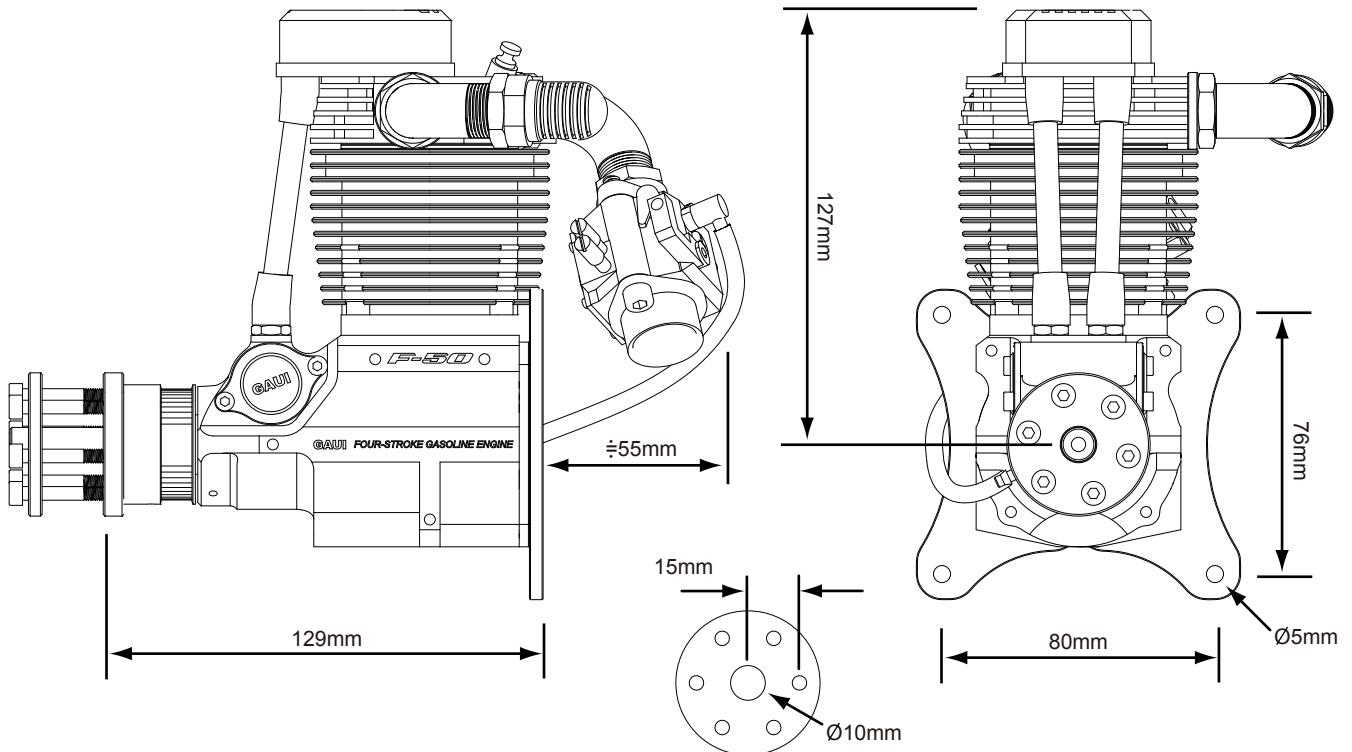

1.Engine assembly.

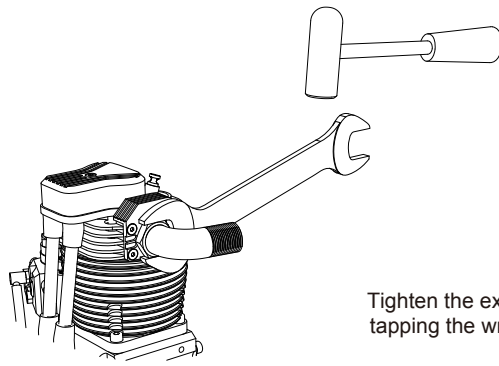

Tighten the exhaust header locking nut by tapping the wrench/spanner with a small hammer.

2.Valve clearance adjustment

The valve clearance should be checked and adjusted after 2 hours of break-in and again after 5 hours. After that, they should only need occasion inspection and adjustment.

Loosen the valve rocker adjustment nut

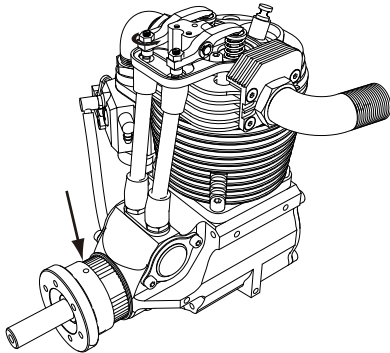

a. Remove the spark plug and rocker arm cover. Turn the crankshaft until the piston is at Top Dead Center.

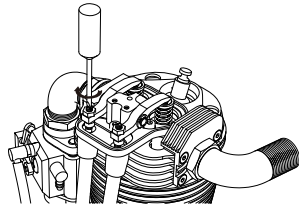

b. Adjust the valve clearance.

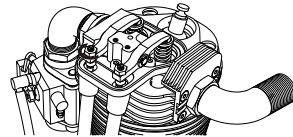

c. After the gap is checked and adjusted, tighten the lock nut securely.

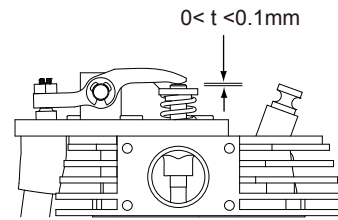

* The gap should be between 0mm and 0.1mm (.004"). The gap should never exceed 0.1mm (.004")

3.Recommended Fuel

The factory recommended fuel is high octane (premium) pump gasoline. Av-Gas is not recommended. Mix the gasoline with high quality 2 stroke oil at a ratio of 20:1.

For example: 1 liter of gasoline mixed with 50c.c 2-stroke engine oil, or 1 gallon of gasoline mixed with 6.4 oz. of 2 stroke oil.

4.The carburetor adjustment

$$H=1\frac{1}{2} \pm \frac{1}{2}$$

$$L=1\frac{1}{2} \pm \frac{1}{2}$$

Low Speed Needle

High Speed Needle

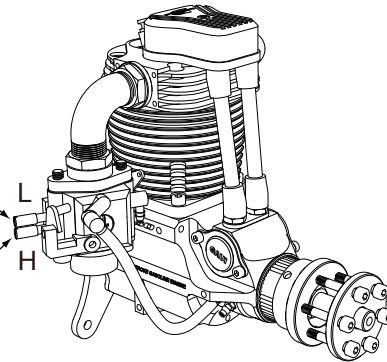

5. Ignition system

Please refer to the ignition system manual.

6.Propeller Installation.

The recommend prop size is 20x10 or 21x10. The propeller must be attached with six 4mm bolts. The threads of these 4mm bolts must screw in at least 8mm deep into the hub.

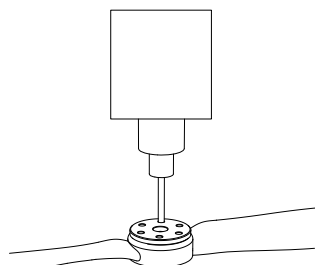
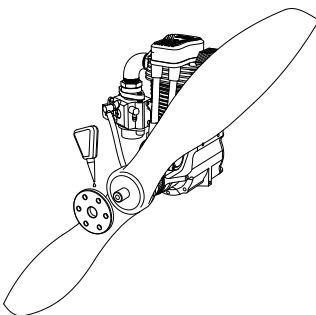

b. Drill holes with 4.1mm, .1614", or #20 drill.

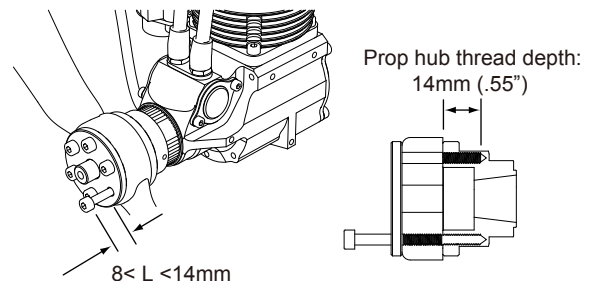

Prop hub thread depth: 14mm (.55")

8 < L < 14mm

a. To drill the prop holes, fix the prop washer on the prop temporarily with a small amount of CA glue.

*Prop thickness will be vary by type and brand. Please use the correct screw length to insure ample thread engagement in the prop hub.

7. Installation of the engine

While breaking in the engine, we recommend running the engine on your plane or a test stand with ample shock absorption. Serious damage can occur to the engine due to vibration frequency with a rigid test stand. We prefer to fly the engine while it breaks in as it is easier and cooler for the engine compared to ground or bench running.

8. **Warning**

- a. Please read the instructions carefully.
- b. Always protect yourself by using gloves and safety glasses when starting the engine.
- c. Be careful of the spark plug pulse! It is in excess of 20,000 volts.
- d. When operating the motor, never stand, or allow anyone else to stand, in front of, or to the side of the propeller. Always stand behind the propeller.
- e. Do not operate the motor if you do not want to be completely responsible for any damage or injury incurred or caused during its operation.
- f. Keep away from the prop while operating the motor. Do not wear loose clothing near the motor or prop.
- g. Do not run the motor near loose material such as dirt, gravel, power cords, ropes, sand, etc. Loose material can be drawn into the turning prop causing injury or damage.
- h. Check that the propeller bolts are tight before every flight.
- i. Always install and use an ignition kill switch to stop the motor.
- j. Adjust the carburetor linkage so that the motor will stop when the carburetor is completely closed.
- k. If you have any questions about any aspect of operating this motor, do not attempt to start or operate it.
- l. Never operate the motor, or fly, alone

This motor could stop at any time, for variety of reasons. Do not fly your plane if you couldn't land it safely when the motor stops.

Maintenance and Repair

Should you ever need to repair your GPOWER engine, genuine spare parts are available through your GPOWER dealer. Do not disassemble the engine unless you have the necessary skills, practice and tools. Please note that any disassembly by unauthorized persons will void the manufacturer's warranty.

Warranty

GPOWER engines carry a two year manufacturer's warranty. In case your GPOWER engine needs a repair in the warranty period, return the engine in its original packing, along with a proof of purchase, to your dealer or send it directly to the manufacturer. Please include a description of the problem and include all details about the fuel, propeller and glow plug used.

Please note that the warranty will be void if any unauthorized disassembly has taken place. Furthermore the warranty explicitly excludes coverage of all damages caused by corrosion, overheating and crashes.

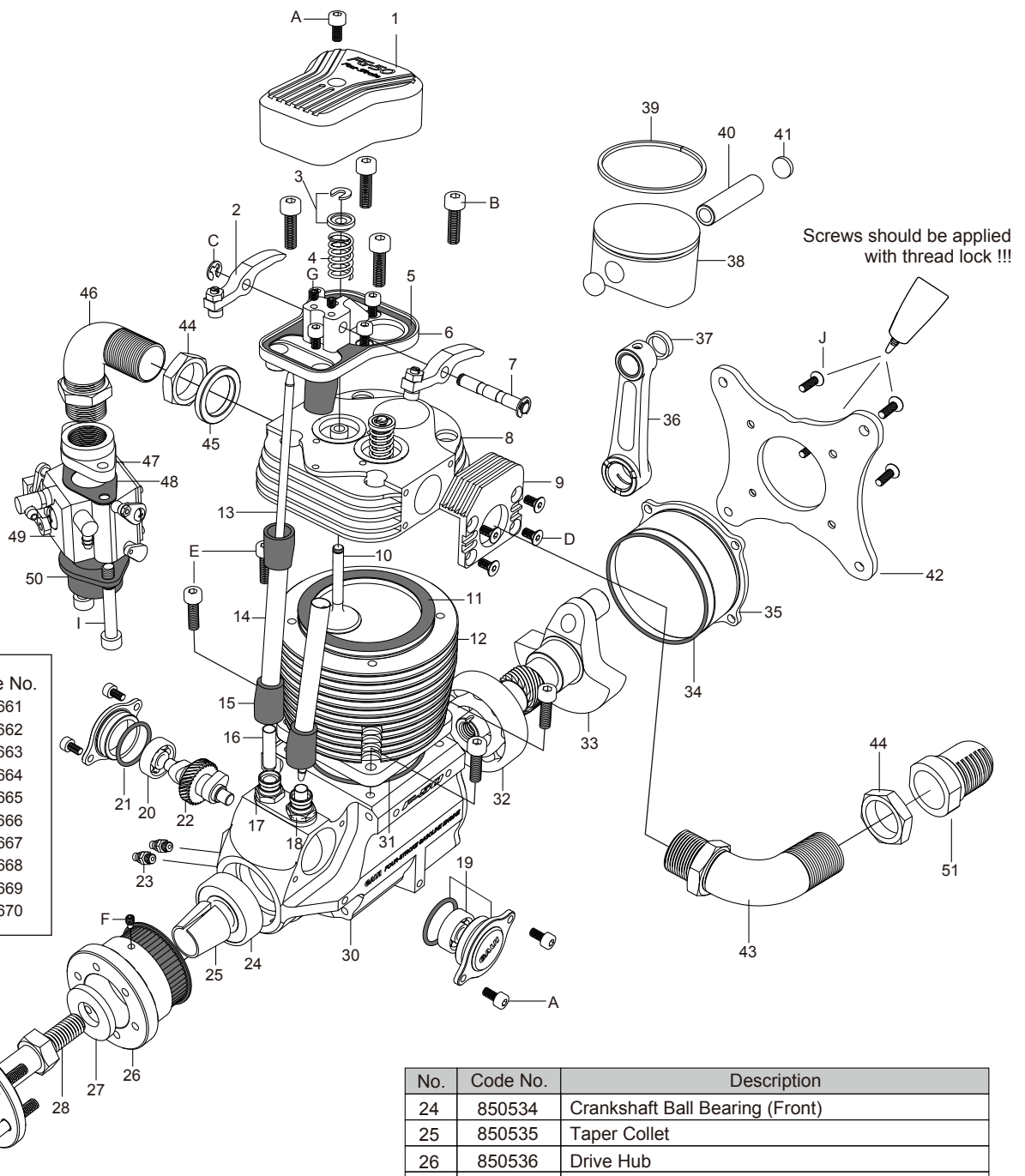

No.	Code No.
A-M3X6 (10pc.)	850661
B-M4X20 (10pc.)	850662
C- 3mm"E"Rings (10pc.)	850663
D-M3X6 (10pc.)	850664
E-M4X16 (10pc.)	850665
F- Screw Pin (1pc.)	850666
G-M3X3 (10pc.)	850667
H-M4X32 (10pc.)	850668
I- M5X40 (2pc.)	850669
J- M4X16 (10pc.)	850670

No.	Code No.	Description
1	850511	Rock Cover
2	850512	Rock Arm (1set.)
3	850513	Valve Spring Retainer Assembly (2set.)
4	850514	Valve Spring (2pc.)
5	850515	Rocker Cover Gasket
6	850516	Rocker Base
7	850517	Rocker Support
8	850518	Cylinder Head
9	850519	Heatsink
10	850520	Valve (1pc.)
11	850521	Head Gasket
12	850522	Cylinder
13	850523	Push Rod (2pc.)
14	850524	Push Rod Cover (2pc.)
15	850525	Rubber Seal (4pc.)
16	850526	Cam Follower (2pc.)
17	850527	Cam Follower Cover (Intake)
18	850528	Cam Follower Cover (Exhaust)
19	850529	Cam Cover Assembly (1pc.)
20	850530	Camshaft Bearing
21	850531	"O"Ring/S (2pc.)
22	850532	Camshaft
23	850533	Breather Nipple (2pc.)

No.	Code No.	Description
24	850534	Crankshaft Ball Bearing (Front)
25	850535	Taper Collet
26	850536	Drive Hub
27	850537	Main Shaft Washer
28	850538	Main Shaft Screw
29	850539	Propeller Washer
30	850540	Crankcase
31	850541	"O"Ring/M
32	850542	Crankshaft Ball Bearing (Rear)
33	850543	Crankshaft
34	850544	"O"Ring/L
35	850545	Cover Plate
36	850546	Connecting Rod
37	850547	Piston Pin Gasket
38	850548	Piston
39	850549	Piston Ring
40	850550	Piston Pin
41	850551	Piston Pin Retainer (2pc.)
42	850552	Engine Mount
43	850553	Exhaust Piper (100°) W/44X2pc.
44	850554	M16X1 Lock Nut (2pc.)
45	850555	Washer (16mm)
46	850556	Intake Piper (90°) W/44X2pc.
47	850557	Intake Manifold
48	850558	Intake Manifold Gasket
49	850559	Carburetor Complete
50	850560	Velocity Stack
51	850561	Muffler